

FloNET (NMEA 2000) Diesel High Flow, K-Series U.S. & Metric

This manual (part # 2000-077-01) applies to the following product part numbers:

- 1) N2TD-6DB-2K
- 2) N20D-3CB-2K
- 3) N2TD-6DC-2K
- 4) N2TD-6DD-2K
- 5) N2TRB6DB-2K
- 6) N20RB3CB-2K
- 7) N2TD-6CB-2K
- 8) N2TRB6CB-2K
- 9) N2TD0-6DD2K
- 10) N2TD0-6DD2K
- 11) N2TD-6ED-2K
- 12) N20D-3BB-2K
- 13) N20D0-3EE2K
- 14) N20D-3DC-2K
- 15) N20D0-3BB2K



INSTALLATION PLANNING



READ ME FIRST - Detailed Mechanical & Electrical Planning Saves Installation Hours!

FloScan systems are not difficult to install. Installing one requires only basic electrical & mechanical skills. With forethought and planning, your system will be installed with few problems.

I. Installation Preparation:

Review the pre-installation booklet and mechanical installation instructions, then survey your vessel. Determine where the Sensor(s), Pulsation Damper(s), NMEA 2000 Interface Hub, Fuel-Tron, & Fuel-Tron Screen Selection Switch are to be mounted. Place them at their approximate locations. Measure fuel line lengths between system components, (Primary Filter, Sensor(s), Damper(s), Engine, and Fuel Tank. Determine fitting sizes and type of fittings needed for each plumbing connection, (JIC, SAE, NPT, NPTF, or Hose Barb).

FloScan Series K High Flow, Diesel system components have 1", and ½" Female NPT ports.

FloScan Series K Standard Flow, Diesel, system components have ¼" Female NPT ports.

FloScan Gasoline High Flow, system components have ½" Female NPT ports.

FloScan Gasoline Standard Flow, system components have ¼" Female NPT ports.

Gasoline Fuel Systems: USCG requires Type A-1 Fuel Hose to be installed between the fuel tank and the engines' fuel inlet connection. Type B-1 may be used if certain safety requirements are met, (33 CFR, Subpart J, 183.558). 33 CFR Subpart J, 183.532 require hose clamps to be made from a corrosion resistant material. To meet American Boat & Yacht Council, (ABYC) standards, the clamps must be made from a corrosion resistant metal, (ABYC, H-24.11.1).

Diesel Fuel Systems: Fuel hose and fittings can comprise a significant portion of the total installation cost. Costs for A-1 Fabric Braid hose & hose barb fittings are approximately 1/3rd the cost of Steel Braid hose & JIC fittings. Both Type A-1 fabric braided hose and wire braided hose meet exactly the same regulatory requirements, (USCG & ABYC) but fabric braid installation costs are far less. For more information contact Ed Sanford, FloScan's Technical Service Manager at extension 302.

Fabric Braid A-1 fuel hose generally uses hose barb fittings. These come in a wide range of Hose Barb to Male NPT, JIC, SAE, & NPTF sizes and combinations. Example: 12 HB X 16 MNPT, (¾" Hose Barb by 1" Male NPT). Steel Braid, Aeroquip type A-1 fuel hose have reusable hose end fittings. Aeroquip type hose ends come in a wide variety of types and sizes, (JIC, SAE, NPT, & NPTF).

Review the electrical installation instructions.

II. Mechanical Installation:

Install or mount the Sensor/Pulsation Damper assemblies, or Sensors, NMEA 2000 Interface Hub, Fuel-Tron and Switch.

III. Plumbing:

Fabric Braid A-1 Fuel Hose: Install the correct HB X MNPT fitting into each fuel system component: Tank, Manifolds, Filter, Sensor(s), Damper(s), and Engine. Assemble fittings using a fuel proof pipe thread sealant. **Never use Teflon Tape.** Referring to the Fuel Flow Schematic, run the fuel hose between system components. Cut to correct length with a pocket or razor knife. Hoses should not be twisted, have adequate slack, an ample radius at all bends and be supported at reasonable distances, approximately 2-4 feet. When clamping hose onto the barbs, use 2 narrow or 1 wide stainless hose clamp on each hose end.

Wire Braid A-1 Aeroquip Type Fuel Hose: Install the correct fitting into each fuel system component: Tank, Manifolds, Filter, Sensor(s), Damper(s), and Engine. Assemble fittings using a fuel proof pipe thread sealant. **Never use Teflon Tape.** Referring to the Fuel Flow Schematic, run the fuel hose between system components. Cut to correct length and install hose ends.

- If you choose to do this yourself, rent a hose-cutting tool and purchase a tube of assembly lubricant.
- Most dealers will cut and assemble both hose ends for \$10 per hose. Some charge as much as \$40.

Hoses should not be twisted, have adequate slack, an ample radius at all bends and be adequately supported at reasonable distances, approximately 2-4 feet. AP-50 copper sealing washers or Flaretite fitting seals may be required to seal JIC & SAE fittings.

IV. Electrical Installation:

If the NMEA 2000 backbone has not been run into the engine room, open and survey your vessel's wire ways and determine how and where it should be run.

Measure the cable length distance from each sensor. Wire each Sensor to the NMEA 2000 Interface Hub with 18 AWG, 3-conductor shielded cable. Always connect the cable shield drain to the vessels bonding system or engine block.

Wire Terminations—referring to the wiring diagram, connect the Sensor(s) to the NMEA 2000 Interface Hub and the Fuel-Tron to its display cycling switch with crimp type butt or ring connectors. Always cover connectors and wire ends with heat shrink tubing.

Isolated Ground Electrical Systems: FloScan manufactures 12 VDC to 12 VDC, (PN 7000-097-00) and 24 VDC to 12 VDC, (PN 7000-096-00) Isolated Ground Power Supplies / Voltage Reducers. These power supplies electrically isolate the FloScan system from ship's power and are used by the Washington State Ferry System and other large steel and aluminum vessel operators. Additionally mounting sensors onto a non-conductive surface and using short lengths of non-metallic fabric braid fuel hose to connect them further isolates the system.

Diesel Fuel is non-conductive but does contain a, "Static Electricity Dissipater" additive to minimize the risk of fuel tank fires and explosions. Even with this additive, the electrical resistance of Diesel Fuel is extremely high and can be considered non-conductive. Installing the FloScan system with Isolated Ground power Supplies, Non-Conductive Sensor Mounting Surfaces and Fabric Braid Fuel Hose will electrically isolate it from the vessel's hull.

V. Pre-Startup:

- ***Always Prime the fuel system before Engine Start-Up.*** This prevents your engine from becoming air-bound. If you have an electric priming or boost pump, circulate fuel for 10 minutes while checking for leaks. If the fuel system does not have an electric priming pump, use the engine's manual pump. Before starting, slightly open or crack the lift pumps' outlet fitting. Pump until all air is purged at the lift pumps' outlet. Before start-up, verify that all fuel system fittings are tight.

VI. Instance Selection:

Refer to the Instance Selection & Operation sheet to determine the correct Instance setting. When known, place the White Recessed Arrow Switch at the correct setting.

VII. Operation Selection:

Refer to the Instance Selection & Operation sheet to determine the correct Operation setting. When known, place the Green Rotary Switch at the correct setting.

VIII. System Start-Up:

Start and run your engines. Look for leaks and other installation problems. If system is not operating properly refer to the Troubleshooting Instructions and correct any deficiencies.

IX. Calibration:

When system is running properly, refer to the calibration instructions and calibrate your system. If installed properly, initial calibration takes less than one hour. After consuming some fuel, final calibration should only take a few minutes.

• The US Code of Federal Regulations, (CFR's) contain no requirement for using Type A-1, A-2, B-1 or B-2, USCG approved fuel hose on diesel powered pleasure vessels. To meet ABYC standards, fuel hose shall comply with the requirements of UL 1114 Marine (USCG Type A) Flexible Fuel-Line Hoses, or SAE J1527 Marine (ABYC H-33.6.1) Fuel-Line Hoses.

USCG approved fuel hose with either fabric or wire reinforcing braid meet the following standards:

Hose Marking	Permeation Rating	2½ Minute Fire Test
USCG Type A-1	100g/m ² /24hrs.	Required
USCG Type A-2	300g/m ² /24hrs.	Required
USCG Type B-1	100g/m ² /24hrs.	Not Required
USCG Type B-2	300g/m ² /24hrs.	Not Required

Table I

Cost comparison between steel & fabric braid A-1 fuel hose on a 50' Diesel pleasure vessel with "Stand-up" engine room:

	Aeroquip A-1 Steel Braid Hose with JIC x MNPT Fittings	A-1 Fabric Braid Hose with HB x MNPT Fittings
48', ¾" Hose / Engine x 2 = 96'	\$9.73/Ft x 96' = \$934.08	\$5.00/Ft x 96' = \$480
Hose End Fittings, 28 Ends	\$11.50 per End, x 28 = \$322	N/A
Hose End Assembly Fee	\$10/Hose x 14 = \$140	N/A
Stainless Hose Clamps	N/A	28ea x \$1.49 = 41.72
Fittings 16 x 12	4ea x \$13.80 = \$55.20	4ea x \$5.39 = \$21.56
Fittings 12 x 12	20ea x \$11.90 = \$238	20ea x \$4.20 = \$84
Fittings 8 x 12	4ea x \$10.75 = \$43	4ea x \$3.59 = \$14.36
Totals:	\$1732.28	\$641.64

Table II

Installation Do's & Don'ts

Do	Don't
Always use a Fuel Proof Pipe Thread Sealant when assembling fittings into fuel system components, (Loctite PST, Rector Seal, or equivalent).	<u>Never use Teflon Tape!</u>
Use thin wall, low pressure, full flow type NPT or NPTF hose barb fittings.	If possible avoid using Push-Lok, Barb-Tite, JIC or SAE swivel fittings. If used, always install Copper AP-50 sealing washers or Flaretite fitting seals onto JIC and SAE swivel fittings.
Double clamp all hose barb fittings.	Minimize the use of 90° elbow fittings.
Install Sensors as far from the engine as practical. Fuel must travel "Up-hill" at least 1 or 2 inches after leaving the Diesel Return Sensor, and all Gasoline Sensors. Verify correct orientation and fuel flow direction.	Avoid bolting or mounting sensor(s) directly onto the engine.
Always install Diesel Forward Sensor/Pulsation Damper assemblies and Gasoline Sensors in the Fuel Pump's Inlet or Vacuum line.	Limit Sensor/Pulsation Damper assembly Operating Pressure to 20 PSI or Less.
Try to use A-1 Fabric Braid Fuel Hose.	If possible avoid using steel braid, "Aeroquip" type hose, hard pipe or metal tube.
Always use 30-micron primary filters on Diesel systems. 20- and 10-micron filters are also acceptable if required by the engine manufacturer.	Avoid 2 or 5-micron primary filters.
Wire with Shielded Cable on Diesel installations. If possible use a dedicated shielded wire pair for Magnetic Pickup Tachometer Senders.	Never use unshielded wires on Magnetic Pickup Tachometer Senders.
Connect all Negative wires to a Battery Minus (-) Buss or directly to the Battery's Negative Terminal. Connect, or "Ground", wire shields / shield drains to the engine block or vessel bonding system.	Never connect Negative, (Battery Minus) wires to the Vessel's Hull, Engine Block, or other machinery.
Always use non-illuminated switches for Totalizer Reset, Port/Starboard Select, Hours/Synch, and GPH/MPG.	Never use illuminated, or back-lit switches.

MECHANICAL OVERVIEW, (NMEA 2000, K Series Systems)

To Ensure System Accuracy, Follow All Installation Instructions.

- Sensor Placement.** Determine where the Flow Sensor, or Flow Sensor-Pulsation Damper assembly is to be installed. Install the sensor, or sensor-pulsation damper assembly so that the two fuel flow arrows, (→ →) or the, (IN and OUT) markings are on a horizontal plane. All orientation arrows, (↑) must be pointing up. The forward sensor or forward sensor-pulsation damper assembly must be installed downstream of the primary filter. Do not install the sensor or either sensor assembly at a high point in the fuel system. This could negatively impact system accuracy by trapping air. The fuel return line between the return sensors' outlet port and fuel tank should be at least 12" long and have a 1 to 2" upward rise. This keeps the return sensor flooded, improving accuracy. Place sensor assemblies in a protected location away from water spray.

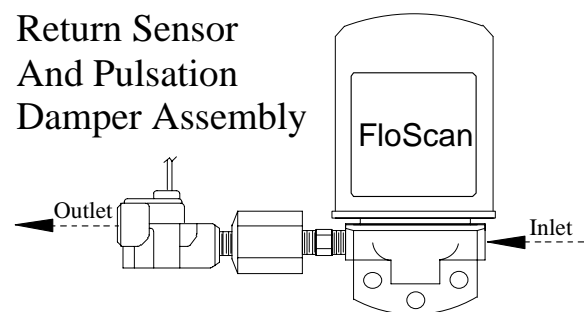
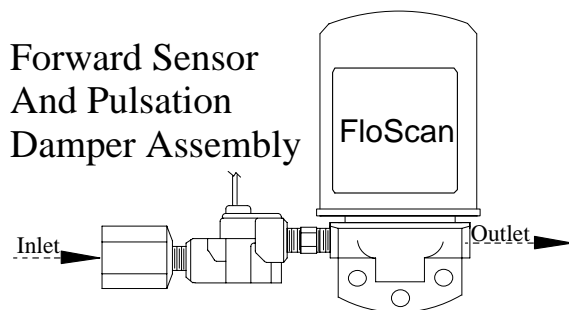
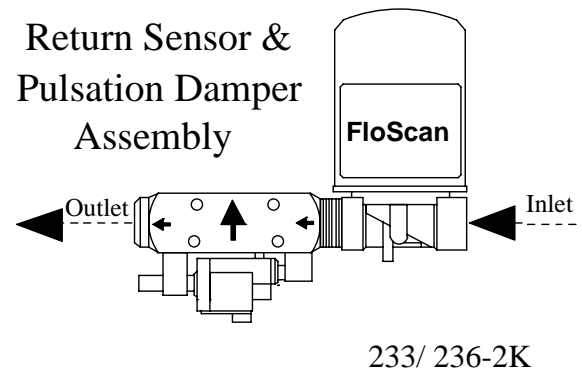
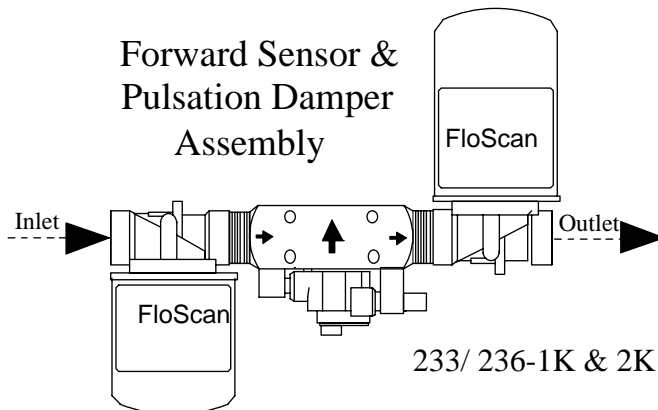

***Caution: Diesel System Components are not designed for use on Gasoline Fuel Systems.**

- Determine fitting type & size.** Minimize the number of elbows and fittings. If swivel fittings are used, (JIC or SAE) their mating surfaces must be sealed with Copper Conical Sealing Washer, (Connie Seals) or fitting seals. Fitting seals may be purchased through Fittings Inc. in Seattle, WA (206) 767-4670, 1-800-552-0632, or a local hydraulic supply house.



- **Select Fuel-Tron Mounting Location, (If Used).** The instruments' face is waterproof and a gasket is provided to seal its bezel to the control panel. Choose a shaded location since direct sunlight may cause the LCD display to temporarily turn dark. This does not damage the LCD, but makes it impossible to read until cooling down. Make a cutout in the instrument panel for the Fuel-Tron. Instrument. It has a 2" diameter and its maximum depth is approximately 1-7/8" minus the thickness of the console panel. Mounting bracket studs extend down another 1/2".
- **Pre-Startup & Installation Check.** *Always Prime the FloScan Fuel Monitoring System.* This is an important step in preventing your engine from becoming air bound. If you have an electric priming or boost pump, circulate fuel for 10 minutes while checking for leaks. If the fuel system does not have an electric priming pump, use the engines manual pump. Before starting, open or crack the lift pumps' outlet fitting slightly. Continue pumping all air is purged and fuel flow from the lift pumps outlet. Before start-up verify that all fuel system fittings are tight.
- **System Start-Up.** Start and run your engines. Survey the installation for leaks and other problems. If the system is not operating properly refer to the Troubleshooting Instructions and correct any deficiencies. When the engine reaches operating temperature increase engine speed to about 1500-2000 RPM. Letting it run for five or ten minute's helps purge residual air from the system.
- Any vacuum leaks between the fuel tank and lift pump will allow air to be drawn into the system. These leaks cause high and/or fluctuating GPH readings. Only severe leaks affect engine performance, but all leaks affect sensor performance and instrument readings. Vacuum or suction leaks occur at improperly sealed primary filters, loose packing nuts on cross over & shut off valves and improperly sealed fittings. Vacuum leaks can also occur from corroded copper fuel lines and chaffed fuel hose, (where it rubs against bulkheads or engine parts). To verify that a suction leak is present, temporarily insert a clear piece of fuel resistant tubing downstream of the Forward Sensors' outlet. Observe the clear hose for at least two minutes looking for bubbles. Bubbles can appear as a constant stream of small bubbles, or as an occasional larger bubble. Tighten all possible leak sources, grease primary filter seals and install fitting seals on JIC/SAE fittings. Continue to observe the clear tubing until it runs clear without any bubbles. Flex or wiggle rubber hose sections while observing the clear tubing. If bubble volume increases inspect the hose and check its fittings. Repair as necessary.
- When idling in neutral, (No Load) GPH fluctuations can also be caused by the governor trying to maintain a steady engine RPM.
- **Calibration.** When the system is running properly, refer to the calibration instructions and calibrate your system. If installed properly, initial calibration takes much less than 1 hour. After consuming some fuel, final calibration should only take a few minutes.

Fuel Flow Schematic – High Flow Diesel Systems, (233 & 236-2K)

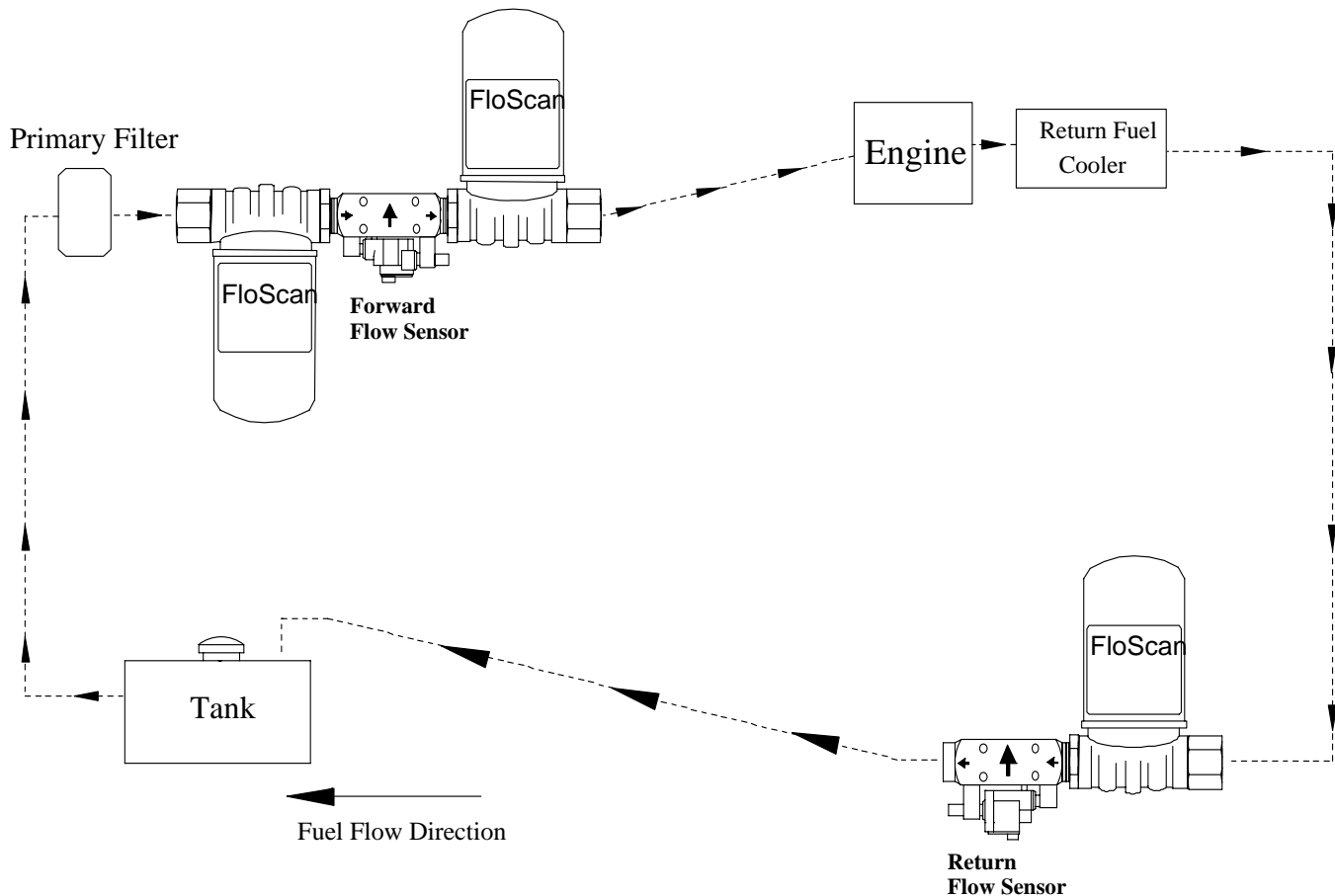

***Caution: Diesel System Components are not designed for use on Gasoline Fuel Systems.**

FloScan Sensor & Pulsation Damper Plumbing Guidelines:

1. Install flow sensor & pulsation damper assemblies with their orientation arrows pointing UP ↑. Fuel must enter through the port marked IN and exit through the port marked OUT. Install the sensor – pulsation damper assembly as far from the engine as practical. Maximizing fuel line length between engine and sensor – pulsation damper assembly improves instrument accuracy.

- Maintaining high flow velocities through the fuel lines minimizes sensor oscillations. Use the smallest approved fuel line diameter for your engine, especially on the return line. Consult the engine owners' manual for more information. To insure that the return sensor remains flooded, install the return sensor – pulsation damper assembly at a low point in the system. Fuel should travel “Up-Hill” upon exiting the return sensor.

(Continued on next page)

- Flow sensors must always be installed downstream of a filter or debris screen (no finer than 30 micron). Particles larger than 1200 microns may jam the sensors' rotor and cause it to fail.
- Flow sensor model numbers are molded into the colored plastic wire cap. Sensors are labeled FORWARD and RETURN and must be installed in these positions for proper operation. A single stand-alone letter stamped into the sensors' body identifies its match code.
- Model *236 sensors are temperature compensated and marked with their Instruments serial number, xxxxF (Forward), xxxxR (Return). *236 Temp-comp sensor kits are precisely calibrated and matched to each instrument. The instrument head serial number must match the flow sensor(s) serial number.
- If there's a shut-off valve in the return line, do not operate the engine with it closed. Fuel system pressure could exceed the systems working pressure of 40 PSI, and may cause a catastrophic system failure. You should either tag the valve so the engine will not run when it is closed for maintenance, or bypass it with a relief valve.

NOTE: Minimize the number of 90° elbows and pipe fittings. Excessive use may create a high vacuum, fuel restricting, pressure drop across the forward part of the fuel system. Refer to the engine owners' manual for maximum, fuel pump inlet vacuum. A vacuum gauge can be used to confirm that the system is within limits.

CAUTION, DO NOT OVER TIGHTEN FITTINGS. Over-tightening may crack the sensor's body or pulsation damper's base. Cracks cause leaks, and fuel leaks sometimes cause catastrophic explosions and fire. Assemble fittings with a Lubricating, Fuel Proof, Non or Semi Hardening pipe thread sealant designed for aluminum and stainless steel threads, (Loctite 567 or equivalent).
DO NOT USE TEFLON TAPE.

TEMPERATURE COMPENSATED		
Forward Sensor	Return Sensor	Kit
*236F	*236E	*6FE-2K
*236E	*236D	*6ED-2K
*236D	*236D	*6DD-2K
*236C	*236C	*6CC-2K
*236C	*236B	*6CB-2K
*236B	*236B	*6BB-2K

NON-TEMPERATURE COMPENSATED		
Forward Sensor	Return Sensor	Kit
233F	233E	3FE-2K
233E	233D	3ED-2K
233D	233D	3DD-2K
233C	233C	3CC-2K
233C	233B	3CB-2K
233B	233B	3BB-2K

INSTALLATION

Fitting/Hose End Installation – 233 & 236-2K High Flow Diesel Sensors

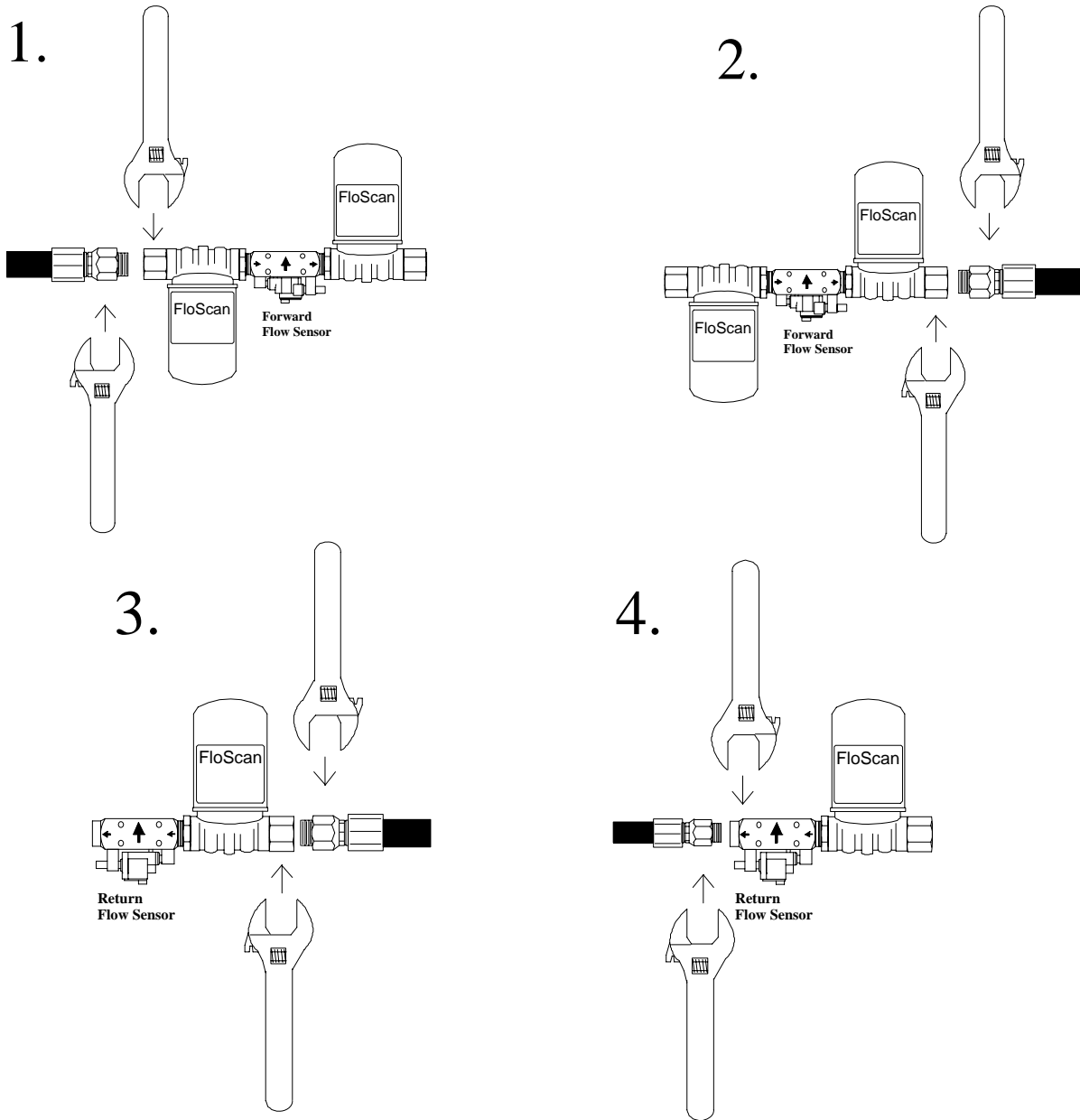

Always assemble hose ends and fittings into sensor assemblies using two wrenches, (at places indicated in the drawings). One wrench is used to turn the hose end or fitting into the sensor assembly. The second acts as a back-up or counter torque wrench and is applied to either the steel SAE/Female pipe adapter fitting, or the Return Sensor's aluminum block at its outlet port.

1K & 2K Hi-Cap Forward Sensor Bracket Assembly

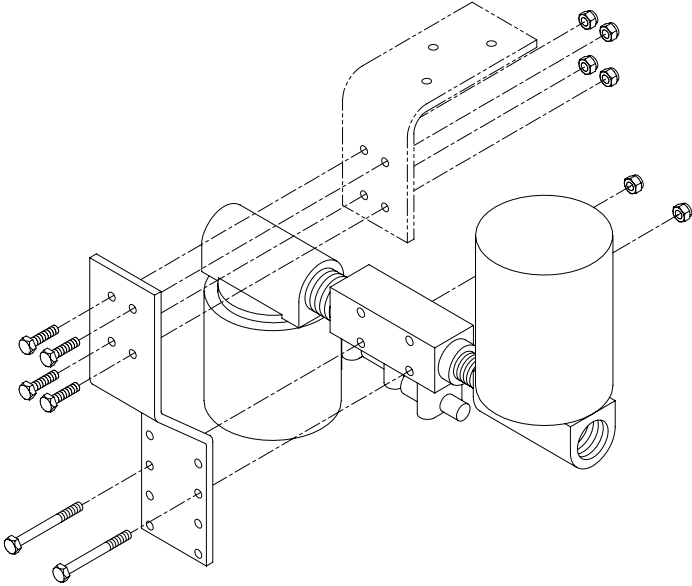
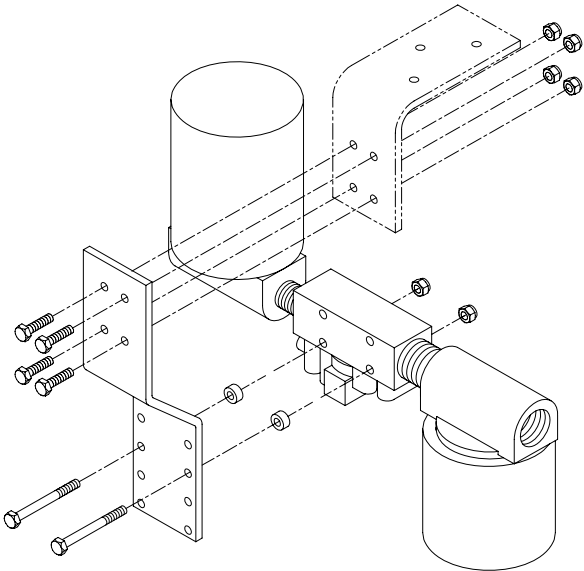
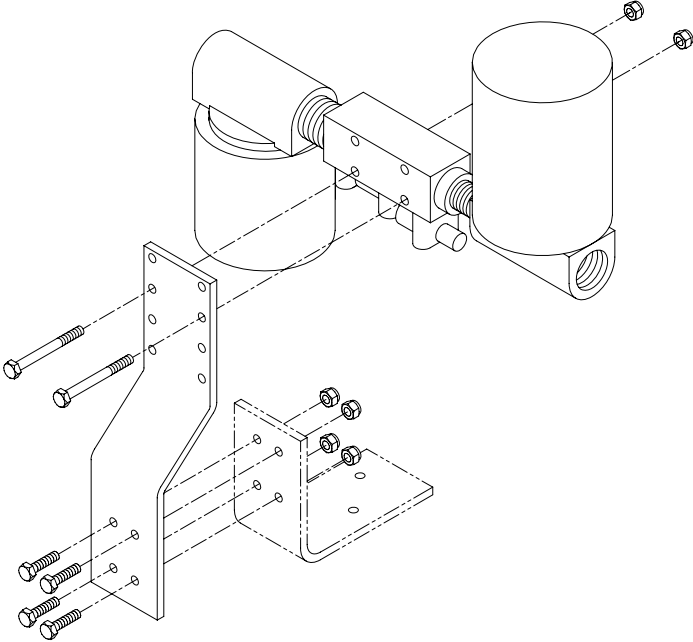
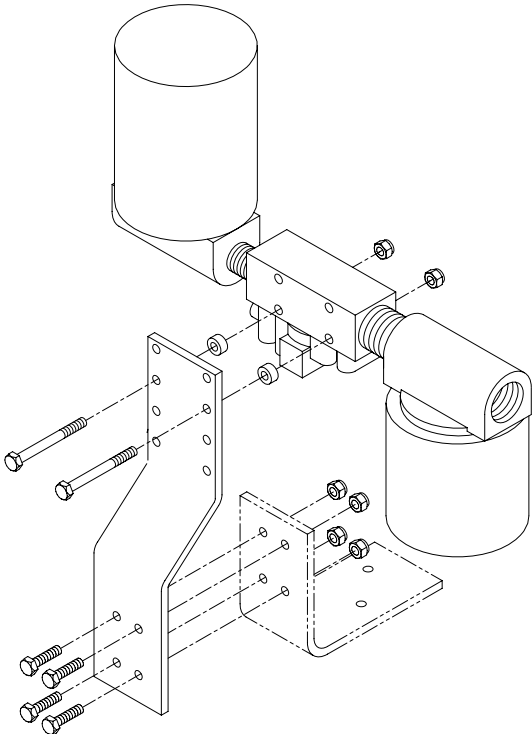

- **90° angle bracket part number 4001-357-00 and mounting hardware available upon request.**

(Please see reverse for Return Sensor Bracket Assembly)

2K Hi-Cap Return Sensor Bracket Assembly

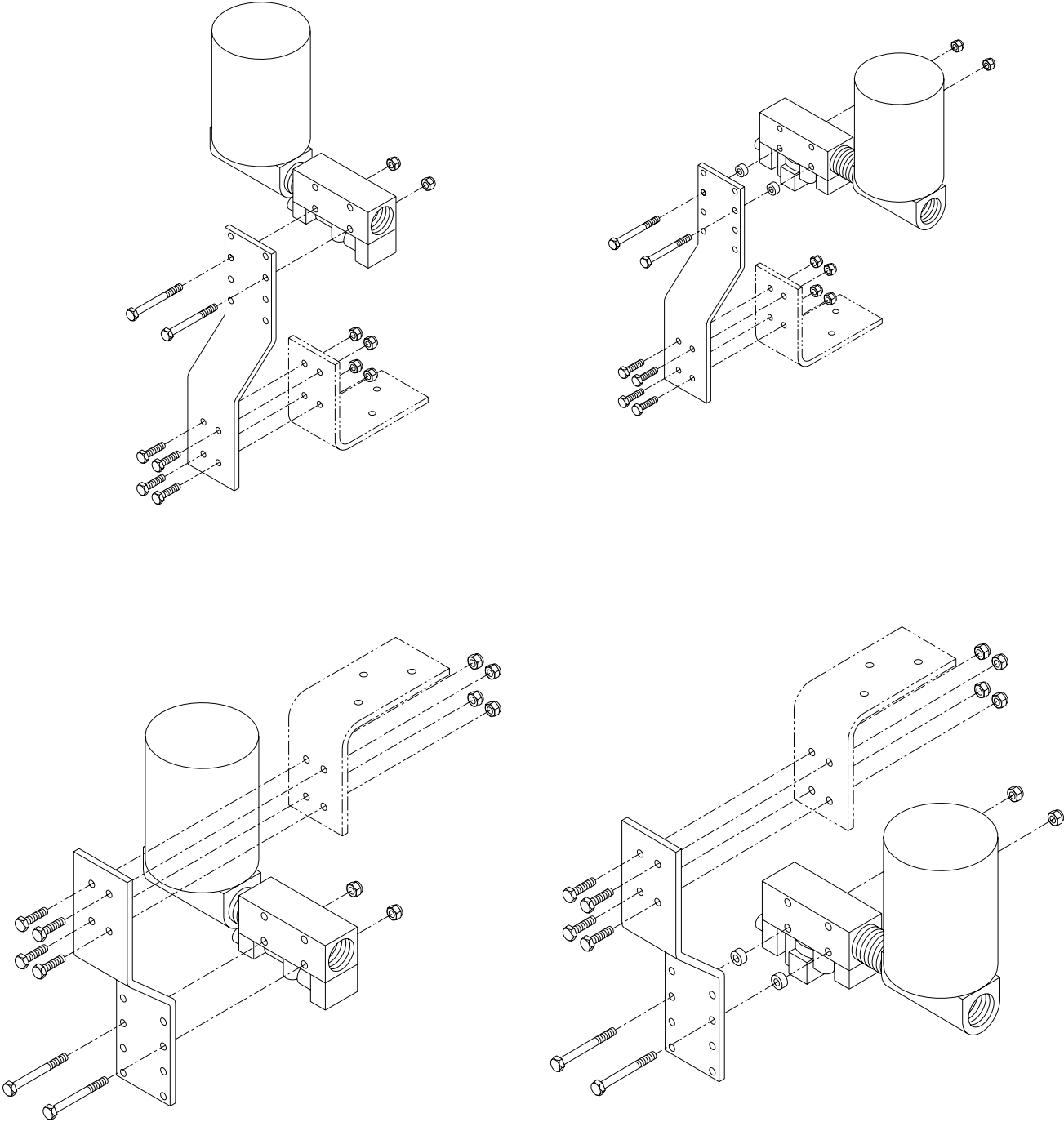

- 90°angle bracket part number 4001-357-00 and mounting hardware available upon request.

FloNET (NMEA 2000) Diesel Fuel Monitoring System

Single Engine FloNET Interface Module Installation using T-Connectors

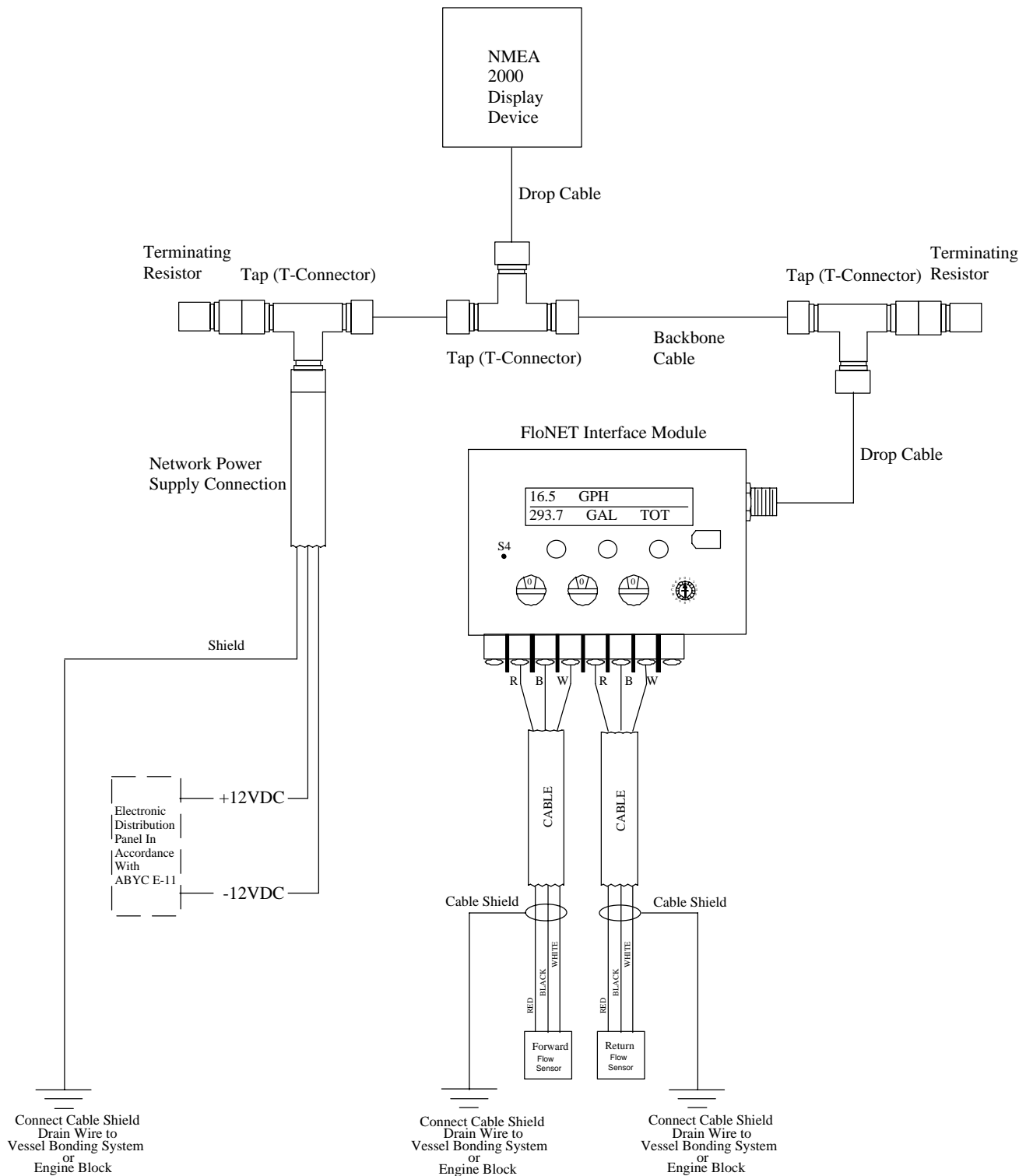

Twin Engine FloNET Interface Module Installation using T-Connectors

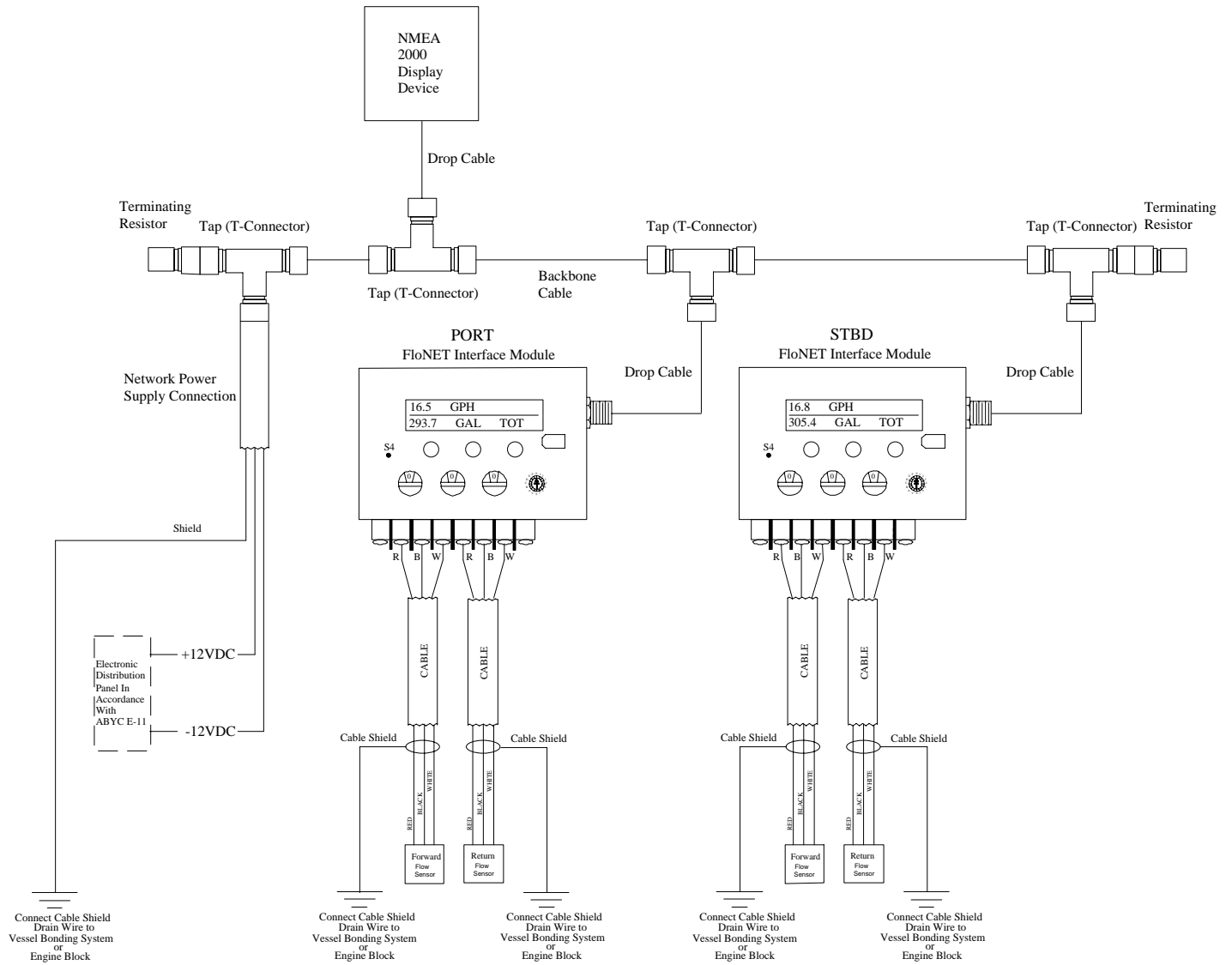

Single Engine FloNET Interface Module & Fuel-Tron Installation using T-Connectors

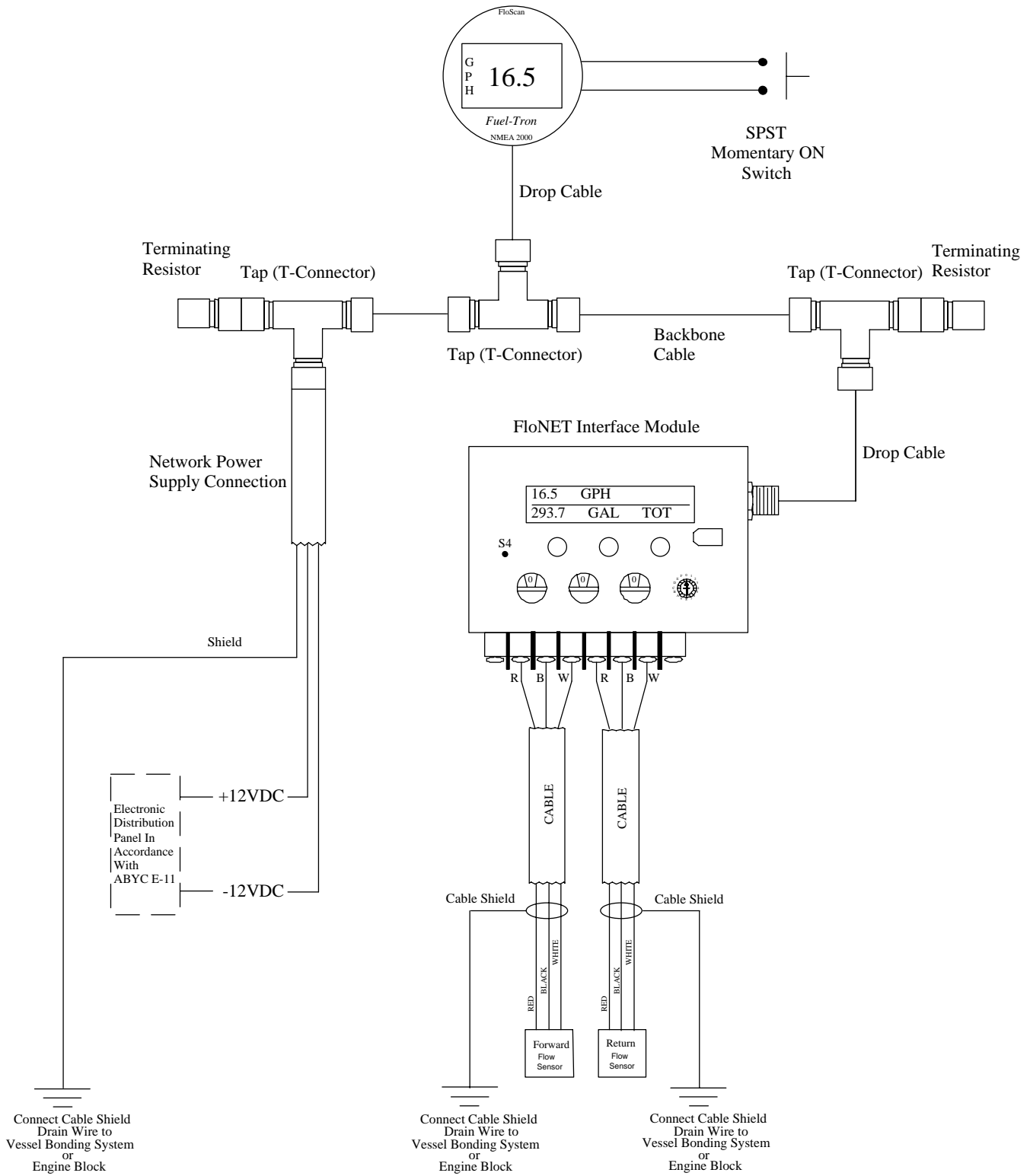

Single Engine FloNET Interface Module Installation using Barrier Terminal Strip Connectors

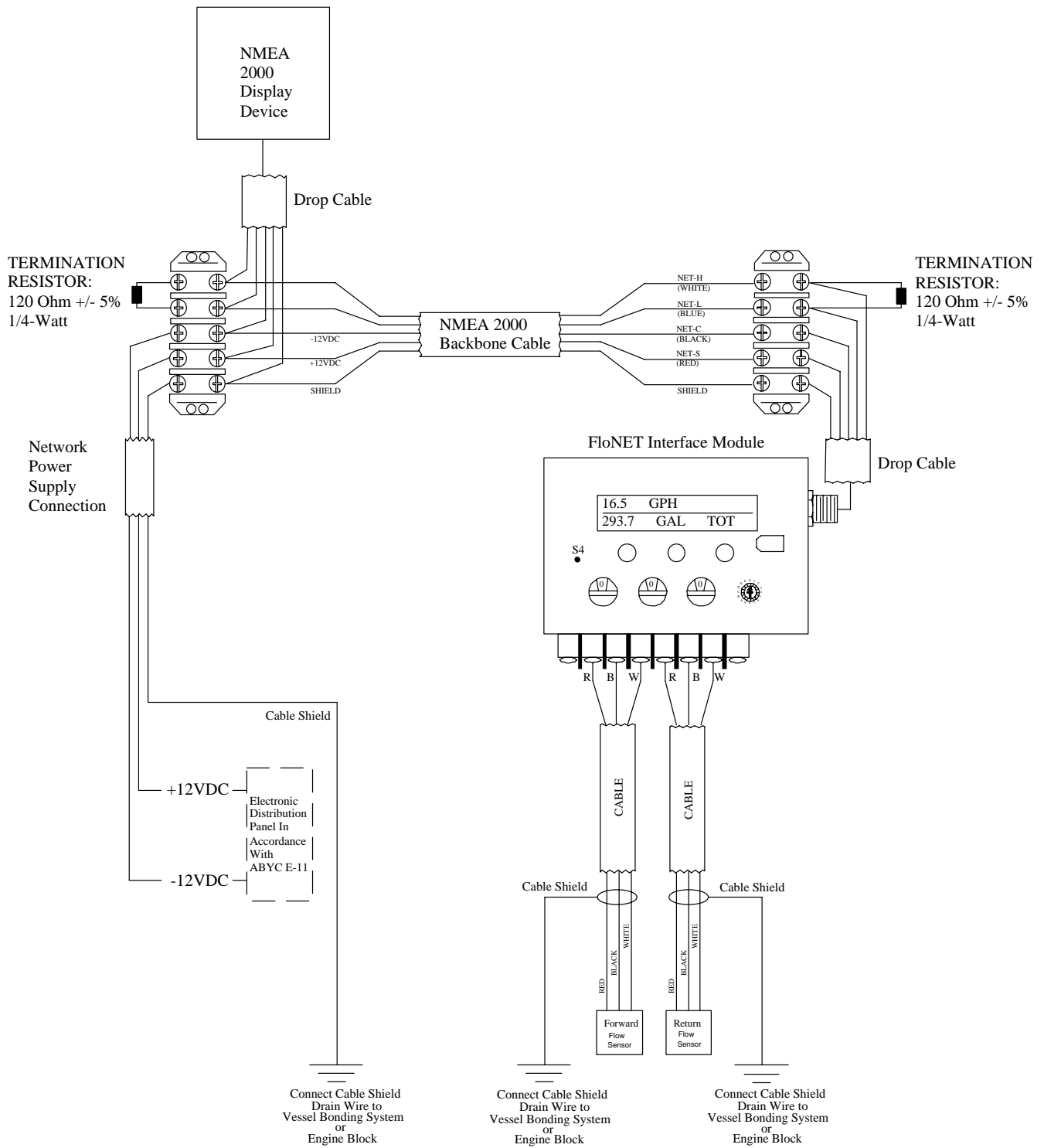

Twin Engine FloNET Interface Module Installation using Barrier Terminal Strip Connectors

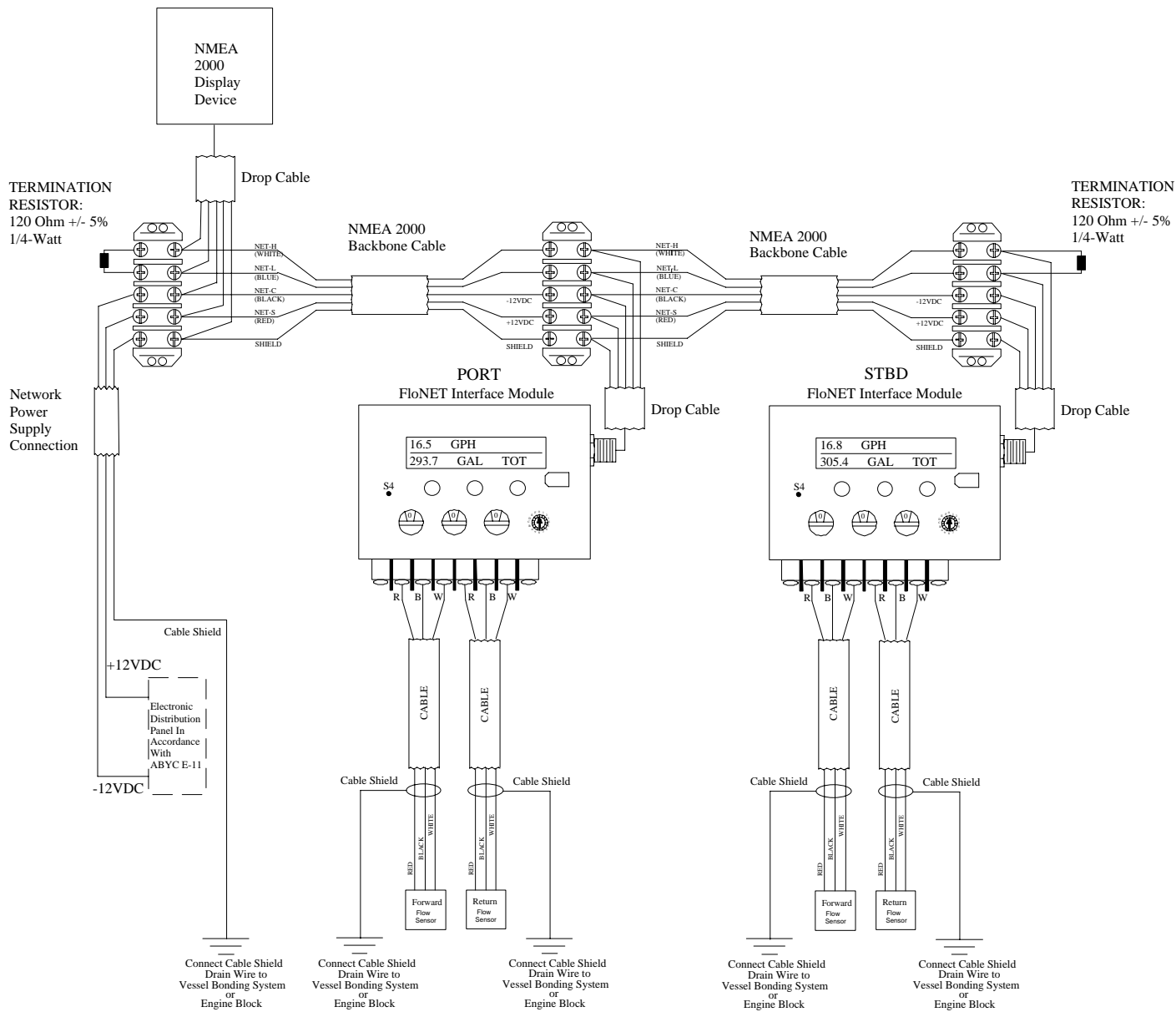

Single Engine FloNET Interface Module & Fuel-Tron Installation using Barrier Terminal Strip Connectors

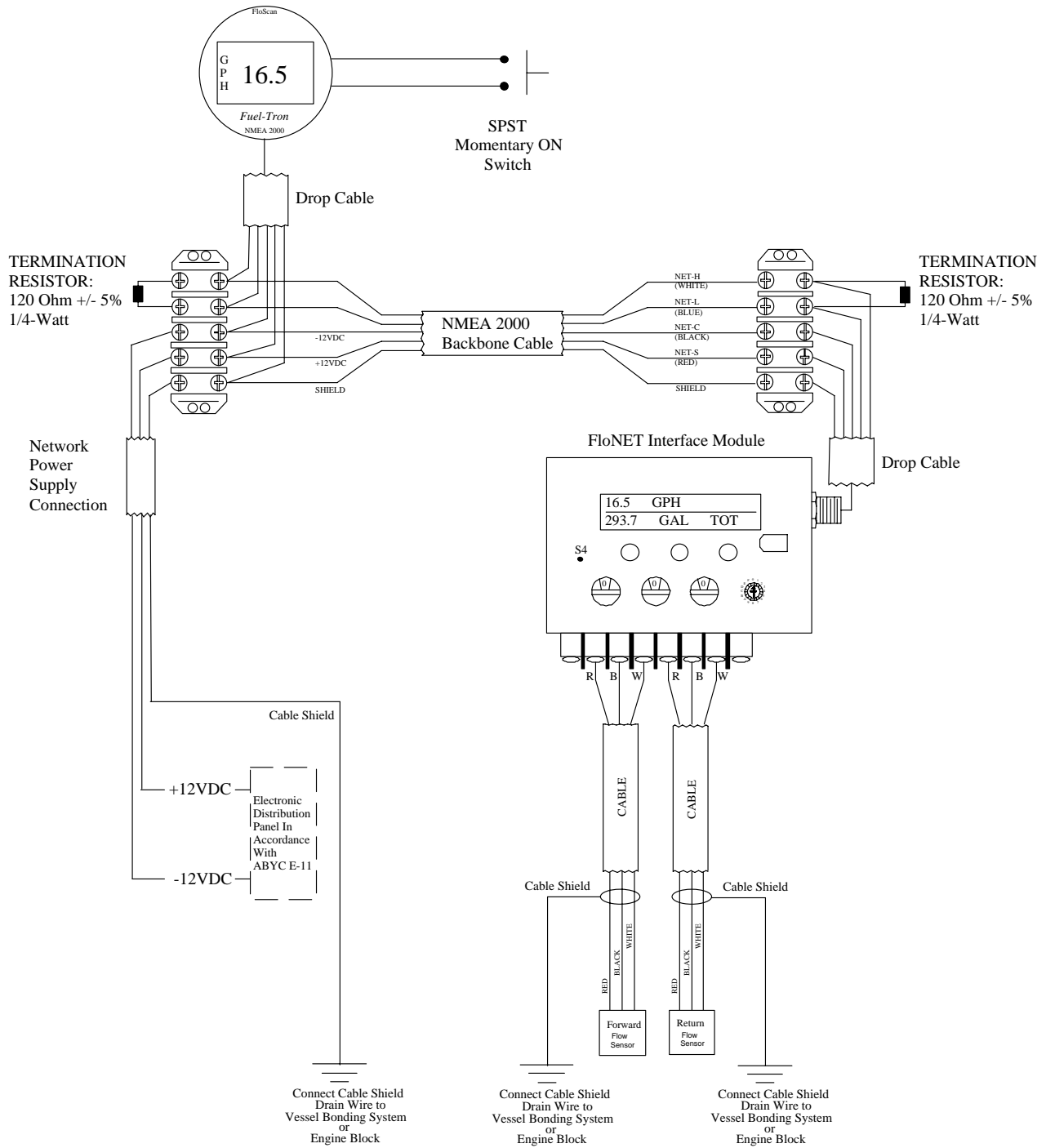

Twin Engine FloNET Interface Module & Fuel-Tron Installation using Barrier Terminal Strip Connectors

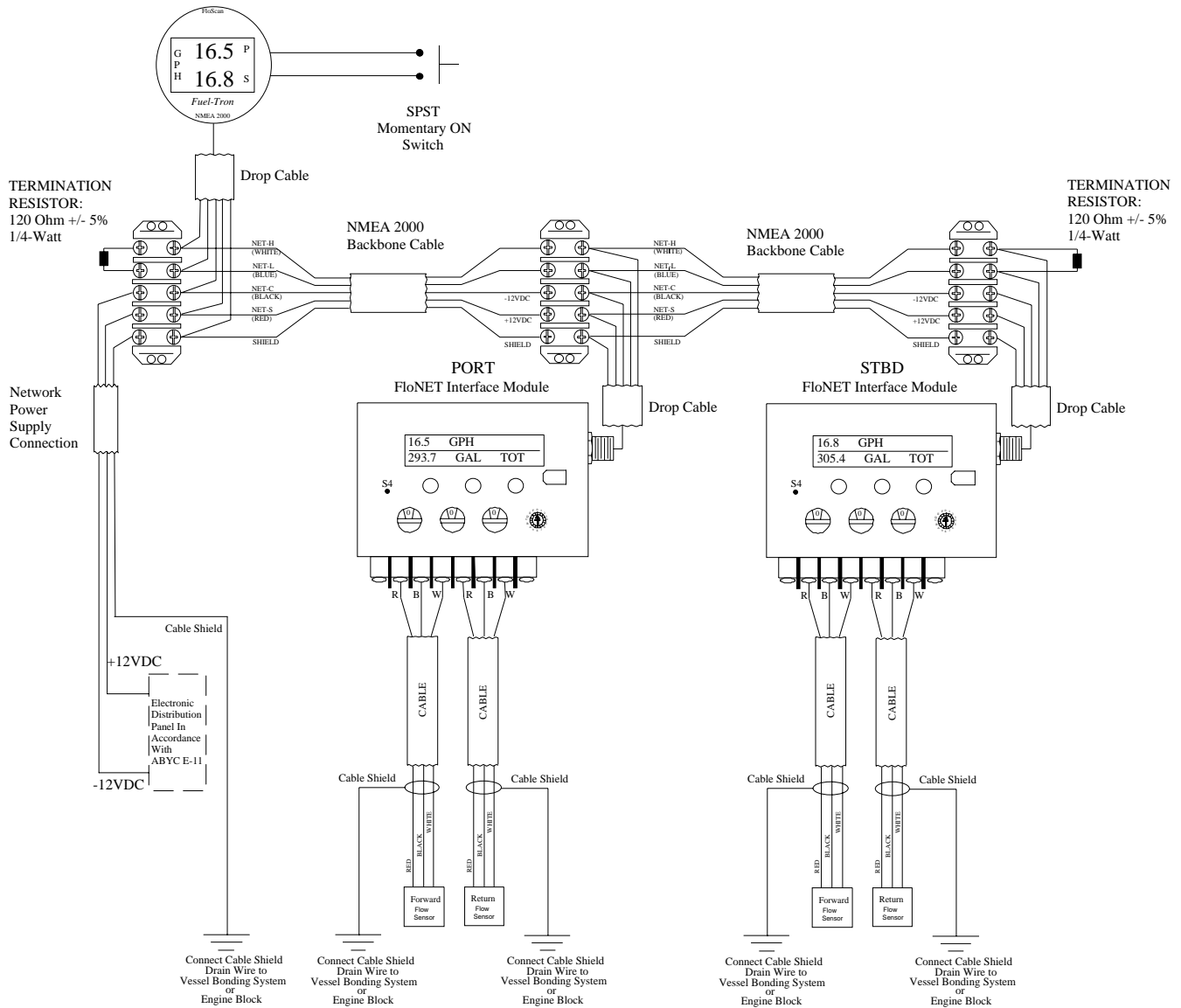

INSTANCE SELECTION & OPERATION

FloNET

FloNET Engine Measurement Instance Selection, (White Recessed Arrow Switch Settings)

The Recessed Arrow Switch is used for setting engine instances.

Mechanical & Diesel Electric Propulsion Engines

- For a Single Main Engine or Port Main Engine: Rotate the **Recessed Arrow Switch** to Position “0”.
- For a Starboard Main Engine: Rotate the **Recessed Arrow Switch** to Position “1”.

Generators and Auxiliary Engines

- For a Single Auxiliary Engine or Port Auxiliary Engine: Rotate the **Recessed Arrow Switch** to Position “2”.
- For a Starboard Auxiliary Engine: Rotate the **Recessed Arrow Switch** to Position “3”.

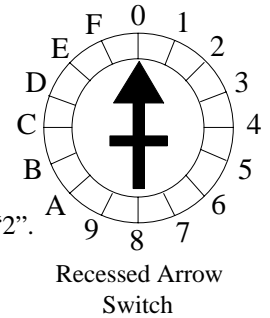

US or Metric Operation Selection, (Green Switch Settings)

- **For US (Gallons):** Rotate the FloNET’s **Green Switch** to Position “0” to display consumption in US Gallons:

FloNET Interface Module

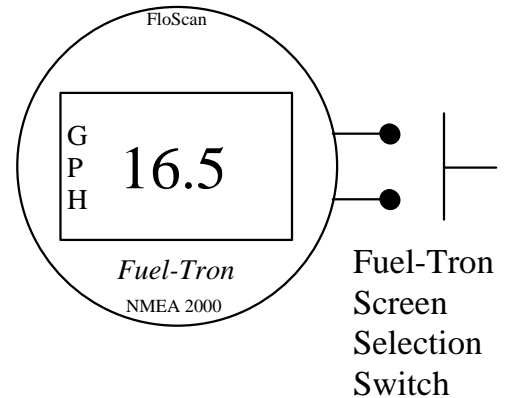
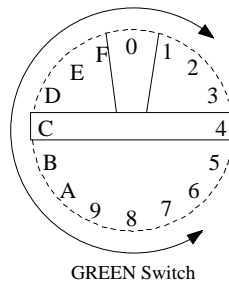
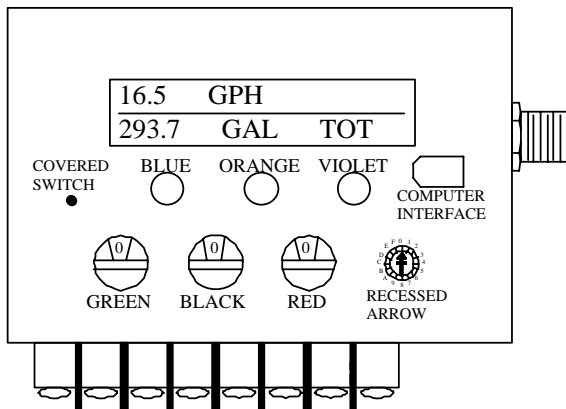

- **For Metric (Liters):** Rotate the FloNET’s **Green Switch** to Position “8” to display consumption in Liters:

FloNET Interface Module

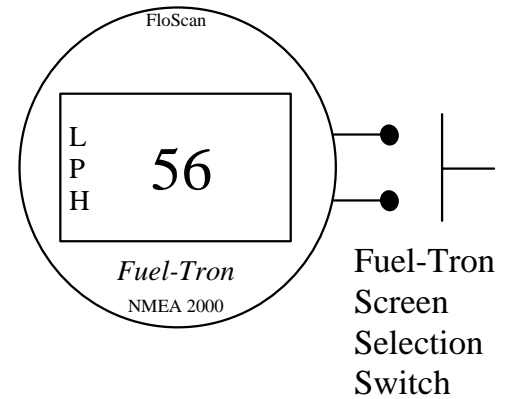
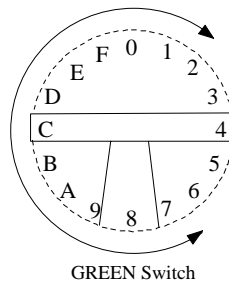
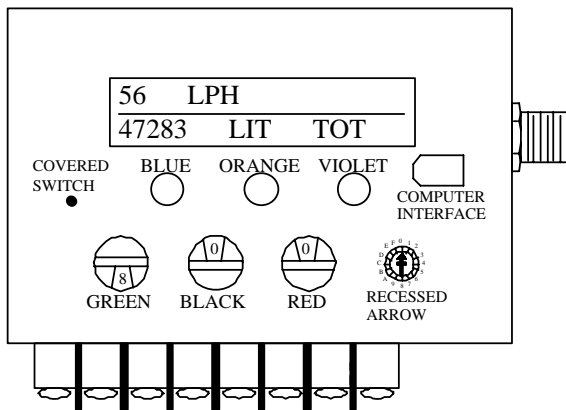

NOTE: All switch adjustments are made on the FloNET.

Flow Consumption (GPH or LPH)

The FloNET display's upper line shows the rate at which your engine is consuming fuel. Depending on the Green Switch setting, the upper line will show consumption in Gallons per Hour, or Liters per Hour.

Total Consumption (Gallons or Liters)

The FloNET display's lower line is the totalizer. It shows the amount of fuel, in either Gallons or Liters, that your engine has consumed since the last time the totalizer was reset.

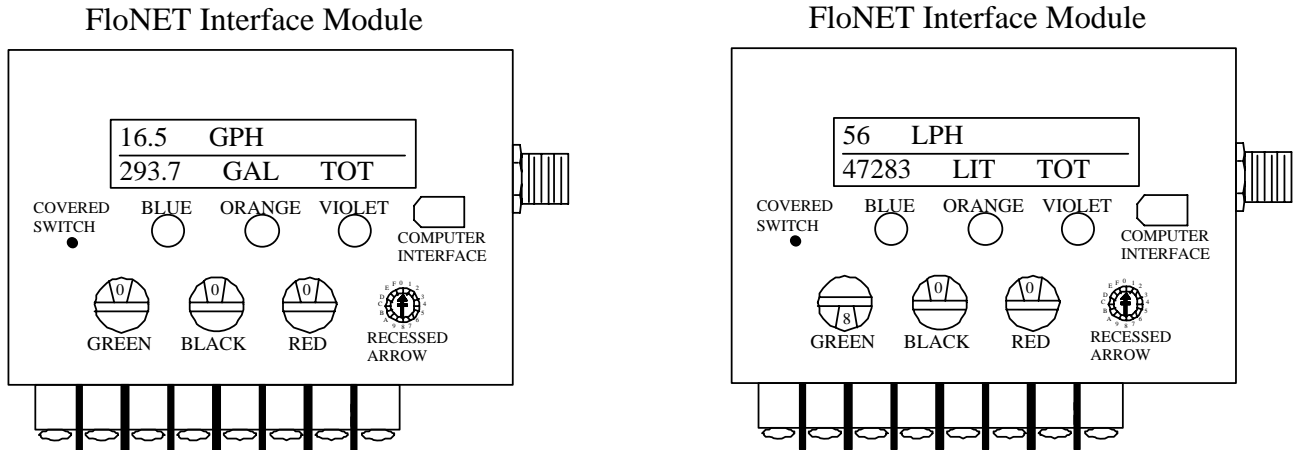

Totalizer Reset

The totalizer is reset or zeroed by pushing the **Blue Switch** and holding it down for 10 to 15 seconds. When the Blue Totalizer Reset Switch is pushed down, the GALLONS or LITERS display will flash for 10 seconds then reset to zero. Flashing indicates the instrument is in reset mode. If the Blue Totalizer Reset Switch is turned OFF, opened or released before the totalizer reads, "0.0", the instrument will NOT reset. If you neglect to turn OFF, open or release the Blue Totalizer Reset Switch, "0.0" continues to flash.

Additional FloNET Switches

- **Software Reset:** The **Orange Switch** is the FloNET's Software Reset, or Interrupt Service Routine, switch. To reset the software, hold the Orange Switch in for 10 to 15 seconds. After 10 seconds the Interface Hub Display's upper line will read HELLO, and the Totalizer will be reset to "0.0".
- **Hardware Reset:** The **Covered Switch** is the FloNET's Hardware Reset, or Microcontroller Restart, switch. To reset the hardware, insert a piece of stiff wire such as a paper clip into the hole marked "S4". Push down on the wire to close the switch and hold for 10 to 15 seconds. After 10 seconds the Interface Hub Display's upper line will read HELLO, and the Totalizer will be reset to "0.0".
- **System Data Switch:** The **Violet Switch** is the FloNET's data display switch. When the Violet switch is pushed the display's upper line will show the system kit number, or system model number. The display's lower line's left side will show the system serial number. The date of manufacture will be shown the right side.

NOTE: If the FloScan FloNET unit is operating properly but the NMEA 2000 monitoring display operates intermittently, is in error, or has no reading check the following:

1. Verify that the NMEA 2000 display is programmed to both receive and display fuel consumption data.
2. Depending on the number of engines on your vessel, verify that the NMEA display can be programmed for Instance 0, 1, 2, 3

If this does not resolve the issue, review the display's instruction manual or contact the manufacturer.

IDLE CONSUMPTION ADJUSTMENT & TOTALIZER CALIBRATION

FloNET Interface Module

FloNET Interface Module

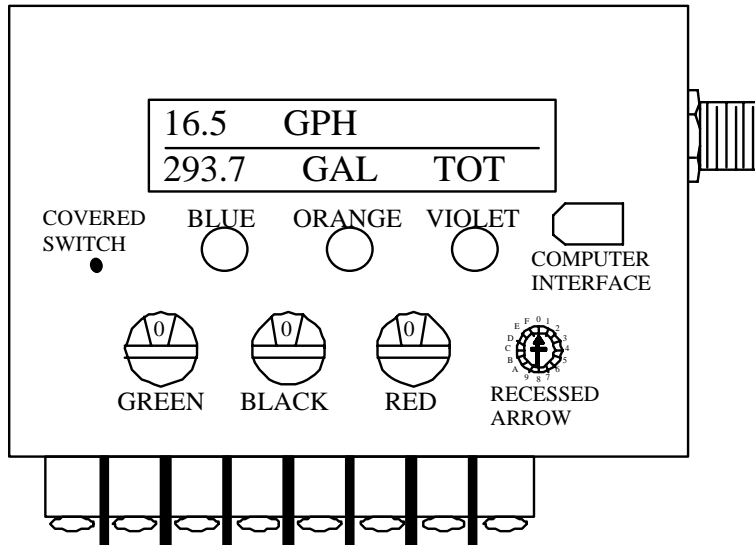

PART I: Generators & Diesel Electric Propulsion Engine Systems

Contact the engine dealer or refer to the engine manual-data sheet and determine the engines:

- No load fuel consumption.
- The 10 % or 25% load, fuel consumption.

Idle Consumption Adjustment for Forward and Return, Two Sensor Generator Systems

- Start and run the engine until it is at operating temperature.
- Rotate the **Red** and **Black** switches to position “0”.
- With no load, verify that the engine is running at the correct RPM (usually 1200, 1500, or 1800).
- Rotate the **Red Switch** until the FloNET GPH or LPH reading matches the manufacturer’s No-Load fuel consumption specification.

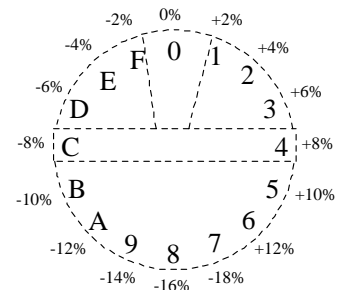

RED Switch

Totalizer Calibration for Forward and Return, Two Sensor Generator Systems

- Put a 10% or 25% load on the generator.
- Rotate the **Black Switch** until the GPH reading matches the manufacturer’s 10% or 25% load fuel consumption listing.

NOTE: Generators turning at 1200, 1500, or 1800 RPM will consume much more fuel at No Load than propulsion engines. If you are unable to obtain the engine manufacturer’s consumption data proceed to Part’s II and IV below. You should triple the readings in Part II, Table 1.

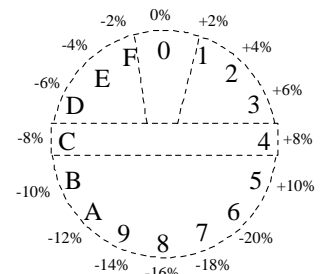

BLACK Switch

PART II: Propulsion Engine Systems

Idle Consumption Adjustment for Forward and Return, Two Sensor Propulsion Engine Systems

- Start and run engine(s) until it is at operating temperature.
- Referring to the switch diagram, rotate the **Red** and **Black** switches to position “0”.
- Increase engine speed to 1800 RPM for one minute. This purges any trapped air from the system.
- Return engine speed to low idle and determine its’ consumption from Table 1 below.

Table 1	No Load Idle Consumption	
HP	Non-Turbo	w/ Turbo
100-400	0.1-0.5 GPH, (1-2 LPH)	0.3-0.7 GPH, (2-3 LPH)
400-750	0.8 GPH, (3 LPH)	1.0 GPH, (3-4 LPH)
750-1000	1.0 GPH, (4 LPH)	1.5 GPH, (5-6 LPH)
1000-1250	2.0 GPH, (7-8 LPH)	2.5 GPH, (9-10 LPH)
1250-1500	3.0 GPH, (11-12 LPH)	3.5 GPH, (13-14 LPH)
1500-2000	3.5 GPH, (13-14 LPH)	4.0 GPH, (15-16 LPH)
2000-3000	4.5 GPH, (17 LPH)	5.0 GPH, (18-19 LPH)

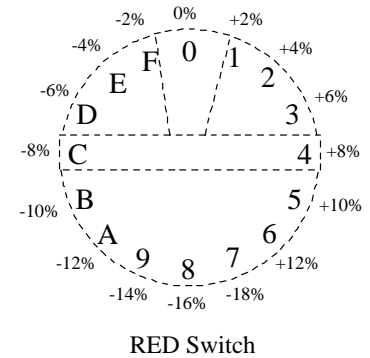

- Rotate the **Red Switch** until the idle GPH or LPH reading matches engine HP from Table 1.

NOTE: At this point idle consumption is approximate. It establishes operating parameters for final calibration.

Part III: Determining Optimum Tank Configuration & Cruise RPM

- Determine the optimum fuel tank configuration for your vessel. If possible, single engine vessels should draw and return fuel to a single tank. On twin engine vessels, try to configure the fuel system so that each engine draws and returns fuel to its’ own dedicated tank. If your twin engine vessel has only a single tank, equal consumption rates for both engines must be assumed.
- Close any cross-connect or limber line valves between tanks during calibration.
- Take your vessel for a short cruise. Using the GPH or LPH reading as a guide, determine the best cruising RPM for the way you normally operate. Don’t be concerned that the readings are slightly off. Calibration is most accurate when done at a single cruising RPM.

Part IV: Final Calibration

- Return to the fuel dock and top off the fuel tank(s).
- Reset the totalizer so that the Interface Hub totalizer reading is zero.
- Operate the generator under load, or take the vessel for a cruise. Once underway steam at your optimal cruising RPM, (Determined in Part III). Consume a minimum of 20 to 30 gallons, (75 to 115 liters) of fuel per engine. Higher consumption gives better accuracy.
- After consuming some fuel, return to the fuel dock and top off the fuel tank(s).
- Compare the FloNET totalizer reading to the fuel pump reading.
- Calculate the percentage difference between the fuel pump & FloNET totalizer readings. **Refer to Examples I & II below.**
- Determine if the FloNET totalizer is reading High or Low.
- Rotate the **Black Switch** until the Interface Hub totalizer reading matches the fuel pump reading.
- Starting at “0”, rotating the BLACK Switch in a clockwise direction increases the totalizer readings by 2% for each click.
- Rotating the switch in a counter-clockwise direction decreases totalizer readings by 2%.
- Totalizer readings can be increased by 10%, or reduced by 20%.

Single Engine Vessels: Please refer to Example 1, Port system, on the following page.

Example 1: Twin engine vessel with two, dedicated fuel tanks, (For single engine vessels with a single tank, use either the Port or Starboard system calibration procedure in Example 1).

After steaming and returning to refuel. The Port tank took 89.7 gallons, (339.5 liters). It's totalizer reads 94.2 gallons, (356.5 liters). The Starboard tank took 93.2 gallons, (352.8 liters) and its' totalizer reads 87.9 gallons, (332.7 liters).

- Using the formula, calculate the percentage difference between the totalizer reading and actual fuel consumption.

$$\text{Port System Calibration} \quad \frac{\text{Difference in Gallons, (Liters)}}{\text{Totalizer Reading}} \times 100$$

- Find the difference between the totalizer and fuel pump readings:
[94.2 gallon, (356.5 liter) totalizer reading] – [89.7 gallon, (339.5 liter) pump reading] = 4.5 gallon, (170.3 liter) difference.
- Determine percentage difference between readings:
[4.5 gallon, (17.0 liter) difference] ÷ [94.2 gallon, (356.5 liter) totalizer reading] = .047 x 100 = 4.7% Higher difference.
- To calibrate, rotate the Port FloNET's Black Switch *counter-clockwise* to position "E", reducing the totalizer reading by 4%.

Starboard System Calibration

- Find the difference between the totalizer and fuel pump readings:
[93.2 gallon, (24.4 liter) fuel pump reading] – [87.9 gallon, (332.7 liter) totalizer reading] = 5.3 gallon, (20.1 liter) difference.
- Determine percentage difference between readings:
(5.3 gallon, (20.1 liter) difference) ÷ (87.9 gallon, (332.7 liter) totalizer reading) = .060 x 100 = 6% Lower difference.
- To calibrate, rotate the Starboard FloNET's Black Switch *clockwise* to position "3", increasing the totalizer reading by 6%.

Example 2: Twin engine vessel with a single fuel tank.

Port System Calibration

After refueling the tank took 182.9 gallons, (692 liters). The Port Totalizer reads 94.2 gallons, (356.6 liters) and the Starboard reads 87.9 gallons, (332.7 liters). With a single tank, you must assume that each engine burned 91.5 gallons, (346.3 liters).

- Find the difference between the totalizer and fuel pump readings:
[94.2 gallon, (356.5 liter) totalizer reading] – [91.5 gallon, (346.3 liter) assumed burn] = 2.7 gallon, (10.2 liter) difference.
- Determine percentage difference between readings:
[2.7 gallon, (10.2 liter) difference] ÷ [94.2 gallon, (356.5 liter) totalizer reading] = .028 x 100 = 2.8% Higher difference.
- To calibrate, rotate the Port FloNET's Black Switch *counter-clockwise* to position "F", reducing the totalizer reading by 2%.

Starboard System Calibration

- Find the difference between the totalizer and fuel pump readings:
[91.5 gallon, (346.3 liter) assumed burn] - [87.9 gallon, (332.7 liter) totalizer reading] = 3.6 gallon, (13.6 liter) difference.
- Determine percentage difference between readings:
[3.6 gallon, (13.6 liter) difference] ÷ [87.9 gallon, (332.7 liter) totalizer reading] = .041 x 100 = 4.1% Lower difference.
- To calibrate, rotate the Starboard FloNET's Black Switch *clockwise* to position "2", increasing the totalizer reading by 4%.

This completes system calibration. The FloNET readings should be within 5% of actual consumption. Calibrating a second time should bring it to within 3%, especially on twin engine, single tank vessels. Larger fuel burns increase calibration accuracy.

Drastically changing operating habits (i.e. changing from mostly cruising to mostly trolling) may affect totalizer accuracy. If this occurs re-calibration may be necessary.

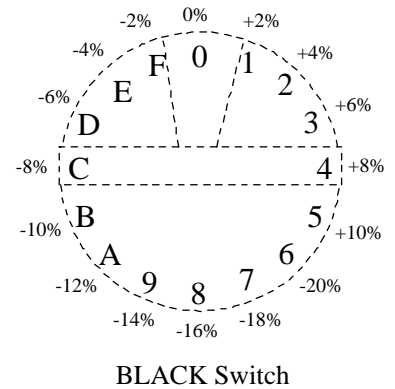

FUEL TRON DISPLAY OPERATION

FloNET (NMEA 2000) Fuel-Tron Instrument

There are a variety of screens that the Fuel-Tron Instrument will display. The different display screens are accessed by pushing the Fuel-Tron Screen Selection Switch. Each time the selection switch is pushed, a different screen is displayed.

NOTE: U.S. Gallons / GPH or Liters / LPH readings are determined by the NMEA 2000 Interface Hub's Green Switch setting.

The Fuel-Tron Screen Selection Switch is also used for resetting fuel consumption totals on the Fuel-Tron Instrument. Toggle to the desired fuel consumption total screen, then push & hold the Fuel-Tron Selection Switch for 10-20 seconds until the fuel consumption total resets back to "0.0".

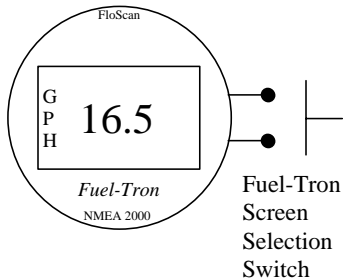

Single Engine Gallons or Liters per Hour

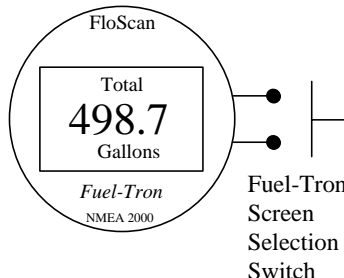

Single Engine Gallons or Liters Consumed

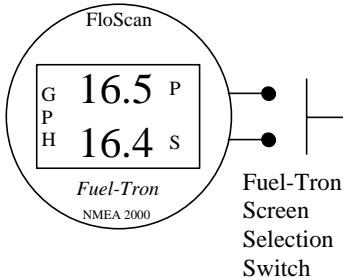

Twin Engine Gallons or Liters per Hour

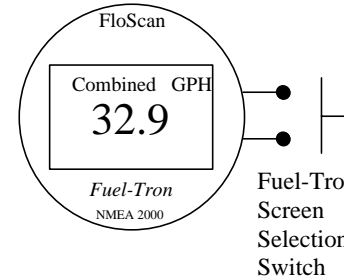

Twin Engine Combined Gallons or Liters per Hour

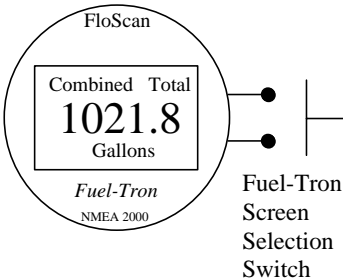

Twin Engine Combined Gallons or Liters Consumed

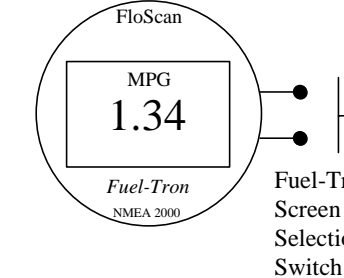

Single or Twin Engine Combined MPG or LPG

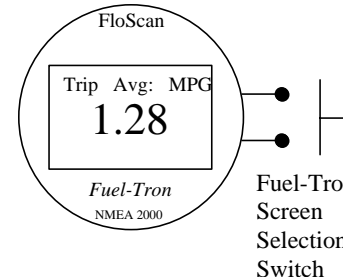

Single or Twin Engine Combined Trip Average Miles per Gallon

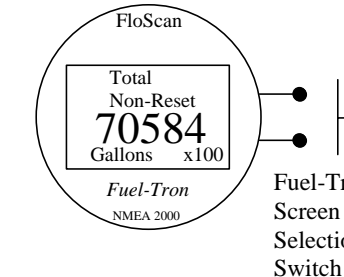

Single or Twin Engine Combined Total (Non-Resettable) Gallons or Liters Consumed

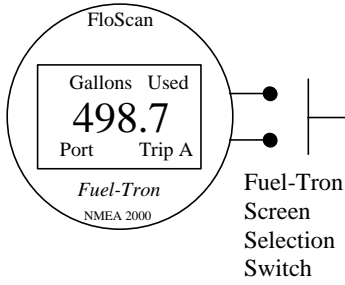

Single or Port Engine Trip A Total

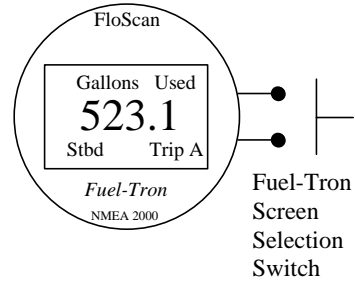

Starboard Engine Trip A Total

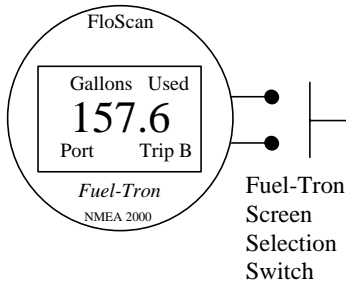

Single or Port Engine Trip B Total

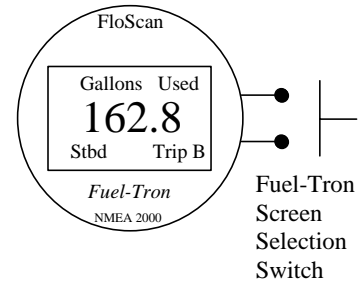

Starboard Engine Trip B Total

TROUBLESHOOTING

FloNET Interface Module, Fuel-Tron Instrument

BEFORE CALLING FOR ASSISTANCE, COMPLETE THESE TROUBLESHOOTING CHECKS AND RECORD YOUR FINDINGS. TECHNICAL SUPPORT REQUIRES THIS INFORMATION BEFORE A RETURN AUTHORIZATION WILL BE ISSUED. IT TAKES ABOUT 20 MINUTES AND IS VERY IMPORTANT IN ANALYZING SYSTEM PROBLEMS.

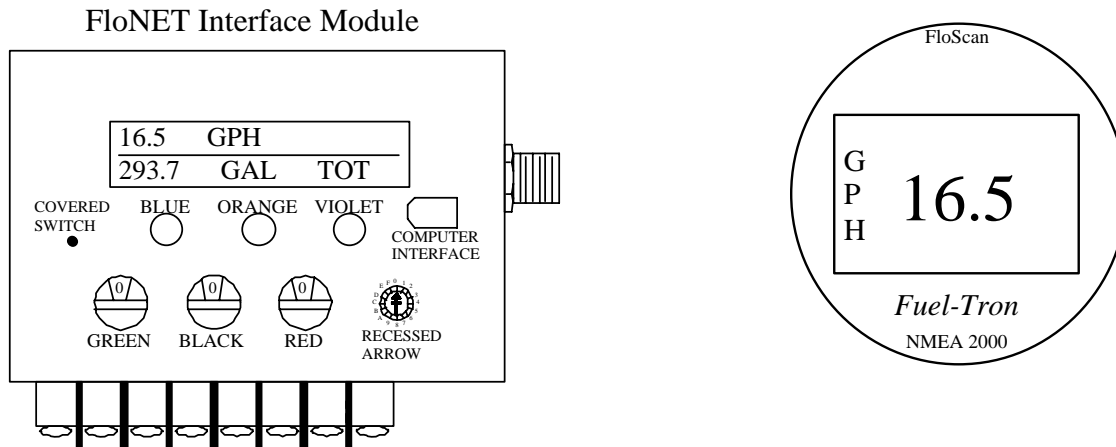

Before starting, please record the FloNET Module and Fuel-Tron Instrument, (if applicable) model number, serial number and switch settings:

MODEL # _____ SERIAL # _____

GREEN _____ BLACK _____ RED _____ RECESSED ARROW _____

FAULT	PROBABLE CAUSE	SEE SECTION
Blank FloNET Module Display	Network Power Reversed	Section II
	Defective NMEA Cable	Section II
	Network Power OFF	Section II
Blank Fuel-Tron Display/No Backlighting	Network Power Reversed	Section II
	Defective NMEA Cable	Section II
	Network Power OFF	Section II
High or Low Totalizer reading. Over 10%.	Calibration	Calibration sheet
	Incorrect flow sensor(s)	
	Sensors Installed backwards	Section VII
	Sensors Wired backwards	Wiring Diagram
	Incorrect switch settings	Calibration sheet
	Vacuum leak	Section V
	Fine Primary Filter	Section VII
Dirty Primary Filter	Section II, Wiring Diagram	
Fluctuating GPH Readings	Vacuum leak / Pulsations	Sections IV, V
No GPH or Totalizer Readings	Wiring	Wiring Diagram
	Sensor orientation	Installation sheet, Section VII
No Forward or Return Sensor Readings	Wiring /Instrument failure	Sections I, II, III, VII
	Sensor Failure	Sections I, II, III
High Forward or Return Sensor Readings	Vacuum Leak	Section V
	Incorrect switch settings	Calibration sheet
	Sensor orientation	Section VII

I. DIAGNOSTIC TEST:

1. Start the engine(s) and allow them to “warm-up” for 5 to 10 minutes.
2. With engine(s) running, place the FloNET Module into Diagnostic Test mode. To do so rotate the Green Switch to Position 1, (for US Gallons models) or Position 9, (for Metric models). This places the instrument into Diagnostic Test mode. The display’s upper line shows raw, (un-calibrated) fuel flow through the Forward Sensor. The display’s lower line shows raw, (un-calibrated) fuel flow through the Return Sensor.

NOTE: Calibration settings do not affect diagnostic mode readings.

EXAMPLES:

US STANDARD

POSITION 2:

F	497.6	GPH
R	518.3	GPH

METRIC

POSITION A:

F	1883	LPH
R	1962	LPH

3. Using the chart below, record Forward and Return sensor readings at IDLE, 1000 RPM, 1500 RPM and 1800 RPM. Circle **S** or **F** to indicate steady or fluctuating readings. If fluctuating, show fluctuation range, (High & Low).

	Forward		Return	
S F		IDLE		S F
S F		1000		S F
S F		1500		S F
S F		1800		S F

4. Rotate the Green Switch through Positions 2, 3, 4 & 5 for US Gallon models or A, B, C, & D for Metric Models. Record the various readings in the chart below the example boxes.

EXAMPLES:

POSITION 1:

287.1	NET	GPH
F&R	DIFFERENTIAL	

POSITION 9:

1086	NET	LPH
F&R	DIFFERENTIAL	

POSITION 3:

F	75°F	FUEL	TMP
R	90°F	FUEL	TMP

POSITION B:

F	24°C	FUEL	TEMP
R	32°C	FUEL	TEMP

POSITION 4:

F	19373	PROGRAM
R	47932	K-FACTOR

POSITION C:

F	19373	PROGRAM
R	47932	K-FACTOR

Differential Flow Rate	Temperature		Display K-Factor		Sensor K-Factor	
	Forward	Return	Forward	Return	Forward	Return

5. Measure fuel-line length between system components and draw a system sketch.

II. SUPPLY VOLTAGE VERIFICATION

NMEA 2000 Backbone Cable with T-Connectors

1. Referring to the connector pin-out drawing and the table below, disconnect the first connector nearest the Network Power Connection and measure voltage across the RED and Black Network Power Supply Connection Wires, (NET-S and NET-C pins or holes). The reading should be approximately 12 to 14 VDC, but not lower than 9 VDC.

NMEA 2000 Connector Pinout

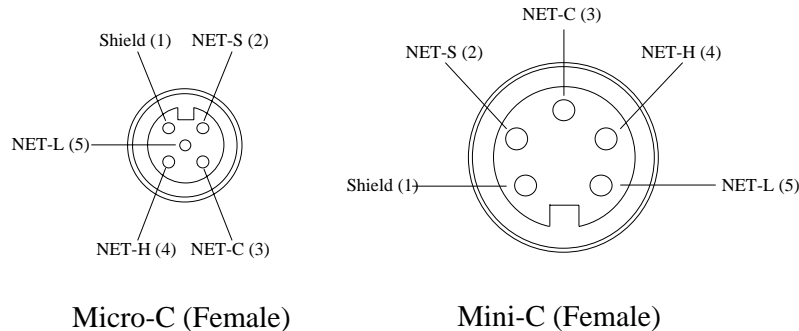

NAME	<i>PAIR</i>	PIN	COLOR
Shield	Drain	1	Bare
NET-S	Power	2	Red
NET-C	Power	3	Black
NET-H	Signal	4	White
NET-L	Signal	5	Blue

NOTE: Micro-Cable Pin-Out is on the left side of diagram. Mini-Cable Pin-Out is on the right.

2. If 12 VDC is not present, measure between the Red power wire and a known good battery minus point. There may be a loose battery minus connection or other wiring problem. Check wiring, switches, fuse, and the 12 VDC power source.
3. 12 to 14 VDC is present between the Red wire and battery minus, there may be a loose battery minus connection, broken wire, open termination or other wiring problem.
4. If voltage is present across the Red & Black Network Power Feed, and the FloNET or Fuel-Tron does not, "Light-Up". Every connector junction between the Network Power Feed connection and the FloNET Module or Fuel-Tron Instrument must be disconnected and checked for voltage, until the problem connector or cable section is found.

NMEA 2000 Backbone Cable with Barrier Terminal Strip Connectors

5. Measure voltage across the RED and Black Network Power Supply Connection Wires at the Power Feed Terminal Strip. The reading should be approximately 12 to 14 VDC, but not lower than 9 VDC.

6. If 12 VDC is not present, measure between the Red power wire and a known good battery minus point. There may be a loose battery minus connection or other wiring problem. Check wiring, switches, fuse, and the 12 VDC power source.
7. If 12 to 14 VDC is present between the Red wire and battery minus, there may be a loose battery minus connection, broken wire, open termination or other wiring problem.
8. If voltage is present across the Red & Black Network Power Feed, and the FloNET Module or Fuel-Tron Instrument does not "Light-Up" supply voltage on every terminal strip must be checked for voltage until the problem connector or cable section is found.

III. SENSOR(S) TEST

1. With engine(s) idling, measure and record voltage between the RED power and BLACK wires on the butt connector side of the Forward Sensor. Voltage readings should be 12 to 14 VDC. _____VDC
2. Move the voltmeters' negative lead to the WHITE signal wire. With engine idling, measure and record the voltage. Readings between 4 and 10 VDC usually indicate a good sensor. _____VDC
3. Stop the engine while observing your voltmeter. Readings should fluctuate between a high of 9 to 12 VDC, and a low of 0 to 4 VDC as the sensors' turbine slows to a stop. _____VDC

NOTE: This may not be seen on digital voltmeters.

4. With engine(s) idling, measure and record voltage between the RED power and BLACK wires on the butt connector side on the Return Sensor, (If used). Voltage should be 12 to 14 VDC. _____VDC
5. Move the voltmeters' negative lead to the White (Signal) wire. With engine idling, measure and record the voltage. Readings between 4 and 10 VDC usually indicate a good sensor. _____VDC
6. Stop the engine and observe the voltmeter. Voltage readings should fluctuate between a high of 9 to 12 VDC, and a low of 0 to 4 VDC as the Sensors' turbine slows to a stop. _____VDC

NOTE: This may not be seen on digital voltmeters.

7. The Sensor(s) may be defective if voltage readings in steps 3 & 5 remain constant. _____VDC

IV. PULSATION PROBLEMS

A stiff anti-siphon valve(s) or miss-plumbed Pulsation Damper(s) can cause fluctuating GPH readings. These are most pronounced at low Rpm's and tend to disappear around mid throttle. They are annoying, and can affect totalizer accuracy. To eliminate, repair or replace any defective valves, or re-plumb dampers according to the Fuel Flow Schematic Instructions.

V. FINDING FUEL SYSTEM VACUUM LEAKS

Fluctuating GPH and High Totalizer Readings are usually caused by a small vacuum leak between the fuel tank and fuel pump inlet. Fluctuations tend to be between 2 and 4 GPH. These vacuum leaks also affect totalizer accuracy, causing it to read 15 to 100% high. Larger leaks produce greater fluctuations and higher readings. They generally do not affect engine performance.

Finding suction leaks can be time-consuming. When approached properly, they can usually be found and repaired quickly. Two common places for suction leaks to occur are at the primary fuel filter - water separator, and/or a loose valve stem packing nut.

Remove the filter housing and coat all o-rings, gaskets and sealing surfaces with a medium to heavy grease, (**Do not use oil**) and reassemble. Grease all valve stem packing's and gently tighten gland nuts. Don't over tighten, valve handles should turn freely. Tighten all hose clamps and compression fittings. Don't over tighten. Run the engine for 5 to 10 minutes observing GPH readings. If you've found the problem, fluctuations should be reduced to less than 1/2 GPH.

If the problem persists, temporarily install a clear piece of fuel resistant hose downstream of the forward flow sensor. Run the engine and watch for a stream of small bubbles in the clear hose, or an occasional larger bubble. Sometimes shining a light through the hose makes bubbles easier to see.

Observe the clear hose while shaking the fuel lines. If the bubble stream continually increases or decreases you've found the leak area. Repair or replace as needed. If this occurs one-time, you probably dislodged some trapped air.

If the leak hasn't been found, the last step is to inspect each pipe joint. Thread sealant should be visible around each joint. If not, that joint is suspect and must be resealed. After resealing run the engine for a few minutes to purge any remaining air. There should now be bubble free fuel running through the clear hose. If bubbles are still present a leak was missed. Recheck your work. After all the leaks are stopped, remove the clear hose.

VI. FUEL FILTERS

A dirty Primary fuel filter or one that is too fine, (2 or 5 micron) tends to draw vapor bubbles out of the fuel, causing fluctuations and high readings. Replace it with a new Engine Manufacturer Recommended Filter, usually 10 or 30-microns.

VII. FLOW SENSOR ORIENTATION

Sensor orientation is critical for proper operation. All Sensors have their inlet and outlet ports clearly marked (**IN**, **OUT**, or **→**). This identifies fuel flow direction. The Sensor must be, "Plumbed" correctly for it to operate properly. If there is an additional single arrow on the Sensor body it is crucial that this single arrow points up **↑**.

VIII. LOW RPM OPERATION

At idle, under a No Load condition, it is common for GPH readings to fluctuate slightly. These fluctuations are caused by the engine governor regulating fuel flow to maintain a steady engine RPM.

**This concludes system testing. If problems with your system persist,
contact FloScan Technical Support with test results.**

