

Installation / Troubleshooting Manual

MFI, Diesel, NMEA-PULSE 9800 K Series Combination, HI-CAP, with Magnetic Pick-up, AC Signal Generator, or Alternator Pick-up Tachometer

This manual (part # 9000-020-02) applies to the following product part numbers:

- 1) 940M-3BB-2K
- 2) 940M-3CB-2K
- 3) 940M-3DC-2K
- 4) 940M-3ED-2K
- 5) 940M0-3ED2K
- 6) 94TM-6DD-2K
- 7) 980M-3BB-2K
- 8) 980M-3CB-2K
- 9) 980M-3CC-2K
- 10) 980M-3DB-2K
- 11) 980M-3DC-2K
- 12) 980M-3DD-2K
- 13) 980M-3ED-2K
- 14) 980M-3EE-2K
- 15) 980M0-3BB2K
- 16) 980M0-3CB2K
- 17) 980M0-3DB2K
- 18) 980M0-3DC2K
- 19) 980M0-3DD2K
- 20) 980M0-3ED2K
- 21) 98TM-6BB-2K
- 22) 98TM-6CB-2K
- 23) 98TM-6CC-2K
- 24) 98TM-6DB-2K
- 25) 98TM-6DC-2K
- 26) 98TM-6DD-2K
- 27) 98TM-6ED-2K
- 28) 98TM-6FD-2K
- 29) 98TM-6FE-2K
- 30) 98TM0-6CC2K
- 31) 98TM0-6DC2K
- 32) 98TM0-6DD2K
- 33) 98TM0-6ED2K

Wiring Connections, Twin Diesel One Series 95/96 NMEA 0183 Input Multifunction Meter One Series 85/86 Pulse Output Multifunction Meter

To insure years of trouble-free operation, please read all of these instructions carefully before beginning your installation

Your twin diesel kit contains one NMEA kit and one Pulse kit. The Pulse kit provides fuel flow information from the engine. It is installed on to the NMEA head on the other engine. The twin kit comes with a special cable harness with all the cross connections required between the two meters already made for you. Follow the electrical connection steps listed below after you have completed the mechanical part of the installation. The twin install kit includes a wiring connection schematic, showing the NMEA unit on the PORT side and the Pulse unit on the Starboard side. The meters are shown looking aft from the connector side of the meter. If you want the NMEA head on the Starboard side, wherever you find Port write Starboard and vice versa.

All 95T/96T, 85T/86T kits come with the flow sensors labeled with the same serial number as the meter in the kit and are labeled as Feed or Return flow. The serial numbers must stay with the meter they came with and must be installed in the fuel system as labeled.

Follow the steps below and make all the wiring connections to the instrument and engine on one side before proceeding to the instrument and engine on the other side. This greatly reduces confusion and wiring problems. Turn OFF the power to your instrument panel before beginning the electrical installation.

Installing the NMEA instrument (95, 96 Series)

1. Decide whether you want the MPG reading on the Port or the Starboard side of your instrument panel. If you have an existing tachometer, label the signal lead(s) and remove the power + ground leads and the tachometer. Install the meter labeled on the back "NMEA". The lower left-hand window displays either GPH for this engine or total MPG.
2. Plug in the white connector labeled NMEA 0183 to the meter labeled "NMEA" and separate out the wires coming from this connector.
3. See the tachometer section of the "Diesel Installation" sheet (4001-325-00B) for connection of the *yellow* wire, terminal #8 and the *violet* wire, terminal #16.
4. The *black* wire (12"), terminal #5 (system ground) connects to the junction of the black wires from the feed and return flow sensors and goes to battery ground. This instrument uses a single point ground system to reduce noise interference and must have only one connection to battery ground.
5. The *white* wire, terminal #6 (signal) connects to the white wire of the feed flow sensor.
6. The *brown* wire, terminal #14 (signal) connects to the white wire of the return flow sensor.
7. The NMEA meter requires two switches, one for GPH-MPG and one for the *Gallons* reset. Connected the *black* wire, terminal #13 to one of the terminals of the GPH-MPG switch and one of the terminals of the *Gallons* reset switch. Connect the *gray* wire, terminal #2 to the other side of GPH-MPG switch. Mount the switch with ON in the UP position. This puts the meter in MPG mode when the switch is up and GPH mode when the switch is down. Connect the *green* wire, terminal #10 to the other side of the *Gallons* reset switch. This switch can be either a normally open momentary push button or a spring-loaded toggle switch. Mount the switch with ON in the UP position. This puts the meter in the reset mode when the switch is up.
8. See the NMEA 0183 wiring sheet (9000-011-00) for connection of the *white/orange* wire, terminal #15 and the *green/black* wire, terminal #7.
9. Connect the *red* wire, terminal #1 to the engine ON side of the engine key switch.

10. Connect the *orange* wire, terminal #4 to the instrument light power (+12 VDC) and the *black/orange* wire, terminal #12 to the instrument light ground.

Installing the PULSE instrument (85, 86 Series)

1. If you have an existing tachometer on this side, label the signal lead(s) and remove the power and ground leads and the tachometer. Install the meter labeled on the back "Pulse". Plug in the white connector labeled "Pulse" to the meter labeled "Pulse" and separate out the wires coming from this connector.
2. See the tachometer section of the "Diesel Installation" sheet (4001-325-00B) for connection of the *yellow* wire, terminal #8 and the *violet* wire, terminal #16.
3. The *black* wire, terminal #5 (system ground) connects to the junction of the black wires from the feed and return flow sensors and goes to battery ground. This instrument uses a single point ground system to reduce noise interference and must have only one connection to battery ground.
4. The *white* wire, terminal #6 (signal) connects to the *white* wire of the feed flow sensor.
5. The *brown* wire, terminal #14 (signal) connects to the white wire of the return flow sensor.
6. The PULSE meter requires one switch for the *Gallons* reset. Connect the *black* wire, terminal #15 to one of the terminals of the *Gallons* reset switch. Connect the *green* wire, terminal #10 to the other side of the **Gallons** reset switch. This switch can be either a normally open momentary push button or a spring-loaded toggle switch. Mount the switch with ON in the UP position. This puts the meter in the reset mode when the switch is up.
7. Connect the *red* wire, terminal #9 to the engine ON side of the engine key switch.

This completes the wiring section of your installation. Read the "Checking the Installation" and "Checking the Calibration" section on the back side of the "Diesel Installation" sheet (4001-325-00B) to complete your installation.

WIRING DIAGRAM

Series 8500/8600 Pulse Output Multifunction Instrument Series 9500/9600 NMEA Input Multifunction Instrument

* Do not use back-lit, or Illuminated Switches

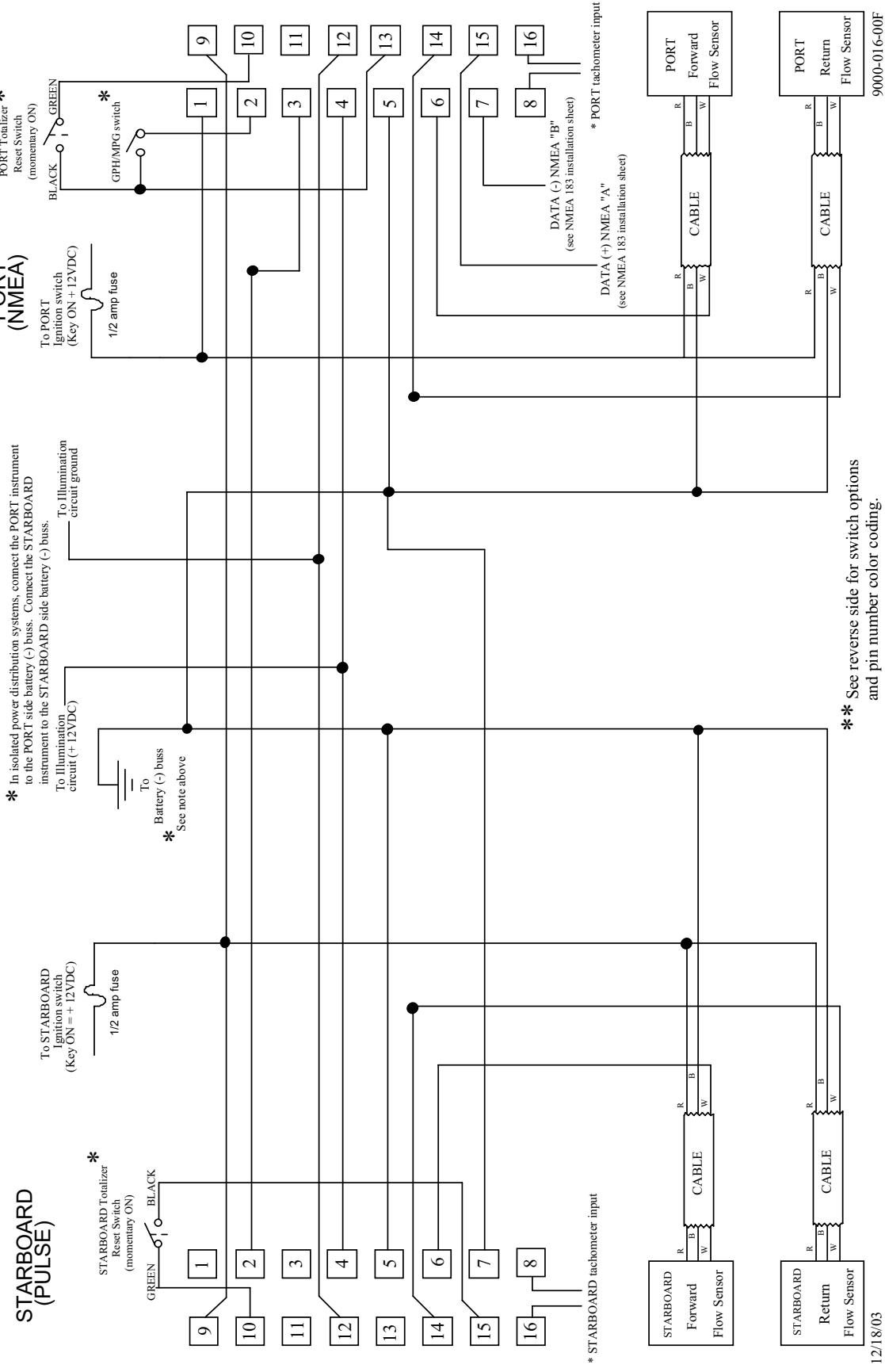

FloScan Instrument Company, Inc.
3016 NE Blakeley Street, Seattle, WA 98105

Tel: (206) 524-6625
email: service@floscan.com

Fax: (206) 523-4961
<http://www.floscan.com>

12/18/03

8500/8600 Pulse Output Multifunction Instrument wiring harness

Instrument Connection Harness

PIN #	FUNCTION
1	RED not connected
2	RED/WHITE + pulse out
3	WHITE/YELLOW + pulse in (Twin applications)
4	ORANGE Illumination + 12VDC
5	BLACK Instrument Ground
6	WHITE forward flow sensor
7	GREEN/BLACK (-) pulse out
8	YELLOW tachometer pick-up

PIN #	FUNCTION
9	RED + 12VDC
10	GREEN Totalizer Reset
11	not connected
12	BLACK/ORANGE Illumination ground
13	BLACK not connected
14	BROWN return flow sensor
15	BLACK Reset Ground
16	VIOLET tachometer pick-up

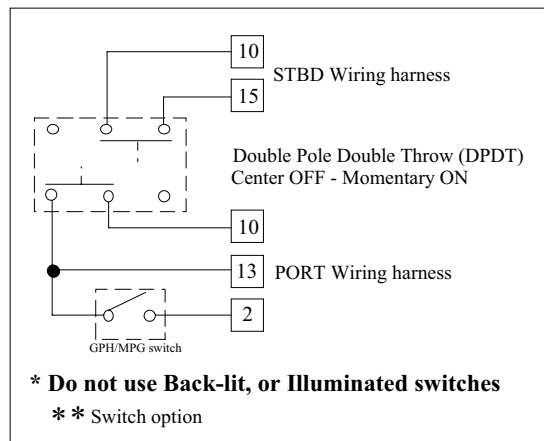
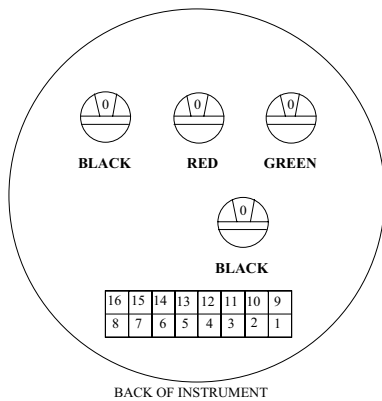

9500/9600 NMEA Input Multifunction Instrument wiring harness

Instrument Connection Harness

PIN #	FUNCTION
1	RED + 12VDC (Twin applications)
2	GREY GPH/MPH select switch
3	WHITE/RED + pulse in
4	ORANGE Illumination + 12VDC
5	BLACK Instrument Ground
6	WHITE forward flow sensor
7	GREEN/BLACK DATA (-)
8	YELLOW tachometer pick-up

PIN #	FUNCTION
9	RED + 12VDC
10	GREEN Totalizer Reset
11	not connected
12	BLACK/ORANGE Illumination ground
13	BLACK switches ground
14	BROWN return flow sensor
15	WHITE/ORANGE DATA (+)
16	VIOLET tachometer pick-up

7 GREEN/BLACK DATA (-) NMEA "B"
 ***Connect to GPS Signal Ground or Battery (-)

15 WHITE/ORANGE DATA (+) NMEA "A"
 ***Connect to GPS Signal Output
 ***See NMEA 0183 Input Installation Sheet

CALIBRATION

Series 7500/7600 8500/8600 9500/9600 Multifunction Instrument, Magnetic Pick-Up (INTEGER)

This instrument **MUST BE** calibrated to your specific engine in the following manner:

1. Determine the number of pulses generated by the Magnetic Pulse Source (Magnetic Pick-Up). Pulses are generated as a gear tooth passes the face of the Pick-Up. Pulses = the number of teeth of the gear (usually the flywheel) multiplied by the number of gear revolutions per crankshaft revolution. Contact your local engine dealer if you need help with finding this. You will need your engine serial number and configuration codes.
2. From the table below determine the number of pulses per crank shaft revolution.

Example: Pulses per crank shaft revolution = 212

3. Follow the row across and find the position to set the RED switch. For the 212 example in step 2, set the RED switch at D.
4. Follow the column up to find the position to set the GREEN switch. For the 212 example in step 2, set the GREEN switch at 3.

		GREEN SWITCH															
		0	1	2	3	4	5	6	7	8	9	A	B	C	D	E	F
RED SWITCH	0	1	2	3	4	5	6	7	8	9	10	11	12	13	14	15	16
	1	17	18	19	20	21	22	23	24	25	26	27	28	29	30	31	32
	2	33	34	35	36	37	38	39	40	41	42	43	44	45	46	47	48
	3	49	50	51	52	53	54	55	56	57	58	59	60	61	62	63	64
	4	65	66	67	68	69	70	71	72	73	74	75	76	77	78	79	80
	5	81	82	83	84	85	86	87	88	89	90	91	92	93	94	95	96
	6	97	98	99	100	101	102	103	104	105	106	107	108	109	110	111	112
	7	113	114	115	116	117	118	119	120	121	122	123	124	125	126	127	128
	8	129	130	131	132	133	134	135	136	137	138	139	140	141	142	143	144
	9	145	146	147	148	149	150	151	152	153	154	155	156	157	158	159	160
	A	161	162	163	164	165	166	167	168	169	170	171	172	173	174	175	176
	B	177	178	179	180	181	182	183	184	185	186	187	188	189	190	191	192
	C	193	194	195	196	197	198	199	200	201	202	203	204	205	206	207	208
	D	209	210	211	212	213	214	215	216	217	218	219	220	221	222	223	224
	E	225	226	227	228	229	230	231	232	233	234	235	236	237	238	239	240
	F	241	242	243	244	245	246	247	248	249	250	251	252	253	254	255	256

NOTE: You can check to ensure the correct number was properly set by putting the gauge into “show switches mode.” To do this, turn the power to the gauge OFF and then back ON. While the display is showing all “8”s, cycle the totalizer – reset switch from the reset position to the run position at least twice. The calibration will be displayed in the RPM window for about twenty seconds. The gauge will then go into diagnostic mode. To put the gauge back into normal operating mode, cycle the power OFF and back ON. Do not touch the reset switch while the display is showing all “8”s.

AC Signal Generator Input

Switch Settings

Poles	Drive Ratio	Green Switch	Red Switch
4	0.5 to 1	1	0
4	1 to 1	3	0
4	2 to 1	7	0
8	0.5 to 1	3	0
8	1 to 1	7	0
8	2 to 1	F	0
30	0.5 to 1	E	0
30	1 to 1	D	1
30	2 to 1	B	3

Alternator Input

The signal from the alternator input comes from one alternator winding before it's rectified. You may notice fluctuations in the tachometer due to belt slippage and varying alternator load.

No Tachometer reading at lower RPMs

Until engine RPM reaches a certain point, the alternators output voltage will be too low for the tach to read. Installing a 12 VDC light across a DC power source (+12 VDC to ground) will increase the alternator load slightly, and cause its output voltage to increase to a usable level.

Calibration

The tachometer can be calibrated by two methods:

I.

Calibrate to an existing tachometer. Rotate the RED and GREEN knobs on the back of the instrument until the two tachometers agree with each other. The accuracy of this method depends on the accuracy of the existing tachometer at the RPM to which you calibrate. Most analog tachometers are accurate to either ± 50 RPM or ± 100 RPM, with the center of the scale being the most accurate. If you set the calibration here and find a difference toward the minimum or maximum ends of the analog tachometer scale, it is probably due to the nonlinearity of the analog meter movement. This method may not be as accurate as #2 below.

II.

1. Calculate the number of pulses per crank shaft revolution. To find the number of crank shaft pulses per revolution, divide the diameter of the engines crank shaft pulley by the diameter of the alternator pulley, and multiply by the number of alternator pulses.

$$\frac{\text{Diameter of Crank Shaft Pulley}}{\text{Diameter of Alternator Pulley}} \times \text{Number of Alternator Pulses} = \text{Pulses per Revolution}$$

2. Locate the number of pulses per crank shaft revolution from the table, select the number closest to the actual pulses per crank shaft revolution. Set the RED and GREEN switches on the back of the instrument accordingly.

Example: A Motorola alternator has 12 pulses (12 pulses per revolution)
 Crank shaft pulley = 10" diameter
 Alternator pulley = 4" diameter

$$12 \times 10/4 = \text{number of pulses per revolution}$$

$$12 \times 2.5 = 30 \text{ pulses per revolution}$$

Series 75/7600(0), 85/8600(0), 95/9600(0) M & I Multifunction Instrument, Totalizer Calibration

This is a three-part calibration procedure. Part one adjusts idle consumption. Part two determines optimum cruising RPM and fuel tank configuration. Part three calibrates for overall accuracy.

PART I: Idle Consumption Adjustment

- Start and run engine(s) until they're at operating temperature.
- Referring to the switch diagram, rotate the Upper and Lower Black Switches to, "0".
- Increase engine speed to 1800 RPM for one minute. This purges any trapped air from the system.
- Return engine speed to low idle and determine its' consumption from Table 1 below.

Table 1	No Load Idle Consumption	
HP	Non-Turbo	w/Turbo
100-400	0.1-0.5 GPH, (1-2 LPH)	0.3-0.7 GPH, (2-3 LPH)
400-750	0.8 GPH, (3 LPH)	1.0 GPH, (3-4 LPH)
750-1000	1.0 GPH, (4 LPH)	1.5 GPH, (5-6 LPH)
1000-1250	2.0 GPH, (7-8 LPH)	2.5 GPH, (9-10 LPH)
1250-1500	3.0 GPH, (11-12 LPH)	3.5 GPH, (13-14 LPH)
1500-2000	3.5 GPH, (13-14 LPH)	4.0 GPH, (15-16 LPH)
2000-3000	4.5 GPH, (17 LPH)	5.0 GPH, (18-19 LPH)

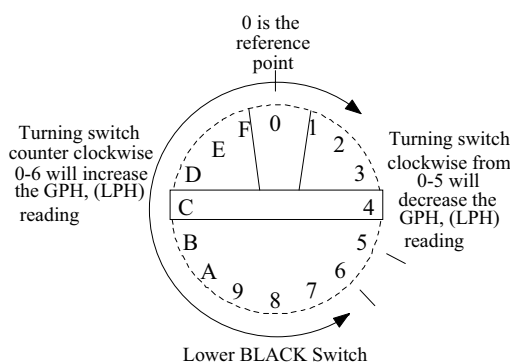

- Rotate Lower Black Switch until the idle GPH, (LPH) reading matches engine HP from Table 1.

NOTE: At this point, idle consumption is approximate. It establishes operating parameters for final calibration. On G model instruments, the **Green Switch** replaces the **Lower Black Switch**. G Instruments were discontinued in 1999.

Part II: Determining Optimum Tank Configuration & Cruise RPM

- Determine the optimum fuel tank configuration for your vessel. If possible, single engine vessels should draw and return fuel to a single tank. On twin engine vessels, try to configure the fuel system so that each engine draws and returns fuel to its' own dedicated tank. If your twin engine vessel has only a single tank, equal consumption rates for both engines must be assumed.
- Close any cross connect or limber line valves between tanks during calibration.
- Take your vessel for a short cruise. Using the GPH, (LPH) reading as a guide, determine the best cruising RPM for the way you normally operate. Don't be concerned that the readings are slightly off. Calibration is most accurate when done at a single cruising RPM.

Part III: Final Calibration

- Return to the fuel dock and top off the fuel tank(s).
- Reset the totalizer so that the GALLONS, (LITERS) window reading is zero.
- Take the vessel for a cruise. Once underway, steam at your optimal cruising RPM, (Determined in Part II). Consume a minimum of 20 to 30 gallons, (75 to 115 liters) of fuel per engine. Higher consumption gives better accuracy.
- After consuming some fuel, return to the fuel dock and top off the fuel tank(s).
- Compare the Gallons, (Liters) window reading to the fuel pump reading.
- Calculate the percentage difference between the fuel pump & Gallons, (Liters) readings; (**Refer to Examples I & II on page 2**).
- Determine if the totalizer is reading High or LOW.
- Rotate the **Upper Black Switch** until the **GALLONS, (Liters)** window matches the fuel pump reading.
- Starting at, "0" rotating the Upper BLACK Switch in a clockwise direction increases the Totalizer readings by 2% for each click.
- Rotating the switch in a counter-clockwise direction decreases Totalizer readings by 2%.
- Totalizer readings can be increased by 10%, or reduced by 20%.

(Continued on reverse side)

Example 1: Twin engine vessel with two, dedicated fuel tanks, (For single engine vessels with a single tank, use either the Port or Starboard system calibration procedure in Example 1).

After steaming and returning to refuel. The Port tank took 89.7 gallons, (339.5 liters). Its' totalizer reads 94.2 gallons, (356.5 liters). The Starboard tank took 93.2 gallons, (352.8 liters) and its' totalizer reads 87.9 gallons, (332.7 liters).

- Using the formula, calculate the percentage difference between the Totalizer reading and actual fuel consumption.

$$\frac{\text{Difference in Gallons, (Liters)}}{\text{Totalizer Reading}} \times 100$$

Port System Calibration

- Find the difference between the totalizer and fuel pump readings:
[94.2 gallon, (356.5 liter) totalizer reading] – [89.7 gallon, (339.5 liter) pump reading] = 4.5 gallon, (170.3 liter) difference.
- Determine percentage difference between readings:
[4.5 gallon, (17.0) liter difference] ÷ [94.2 gallon, (356.5 liter) totalizer reading] = .047 x 100 = 4.7% **Higher** difference.
- To calibrate, rotate the Port MFI's Upper Black Switch Counter-Clockwise to position E, reducing totalizer reading by 4%.

Starboard System Calibration

- Find the difference between the totalizer and fuel pump readings:
[93.2 gallon, (24.4 liter) fuel pump reading] – [87.9 gallon, (332.7 liter) totalizer reading] = 5.3 gallon, (20.1 liter) difference.
- Determine percentage difference between readings:
(5.3 gallon, (20.1) liter difference) ÷ (87.9 gallon, (332.7 liter) totalizer reading) = .060 x 100 = 6% **Lower** difference.
- To calibrate, rotate the Starboard MFI's Upper Black Switch Clockwise to position 3, increasing totalizer reading by 6%.

Example 2: Twin engine vessel with a single fuel tank.

Port System Calibration

After refueling the tank took 182.9 gallons, (692 liters). The Port Totalizer reads 94.2 gallons, (356.6 liters) and the Starboard reads 87.9 gallons, (332.7 liters). With a single tank, you must assume that each engine burned 91.5 gallons, (346.3 liters).

- Find the difference between the totalizer and fuel pump readings:
[94.2 gallon, (356.5 liter) totalizer reading] – [91.5 gallon, (346.3 liter) assumed burn] = 2.7 gallon, (10.2 liter) difference.
- Determine percentage difference between readings:
[2.7 gallon, (10.2 liter) difference] ÷ [94.2 gallon, (356.5 liter) totalizer reading] = .028 x 100 = 2.8% **Higher** difference.
- To calibrate, rotate the Port MFI's Upper Black Switch Counter-Clockwise to position F, reducing its' totalizer reading by 2%.

Starboard System Calibration

- Find the difference between the totalizer and fuel pump readings:
[91.5 gallon, (346.3 liter) assumed burn] - [87.9 gallon, (332.7 liter) totalizer reading] = 3.6 gallon, (13.6 liter) difference.
- Determine percentage difference between readings:
[3.6 gallon, (13.6 liter) difference] ÷ [87.9 gallon, (332.7 liter) totalizer reading] = .041 x 100 = 4.1% **Lower** difference.
- To calibrate, rotate the Starboard MFI's Upper Black Switch Clockwise to position 2, increasing its' totalizer reading by 4%.

This completes system calibration. The Instrument should be within 5% of actual consumption. Calibrating a second time should bring it to within 3%, especially on twin engine, single tank vessels. Larger fuel burns increase calibration accuracy.

Drastically changing operating habits, (Changing from mostly cruising to mostly trolling) may affect totalizer accuracy. If this occurs, re-calibration may be necessary.

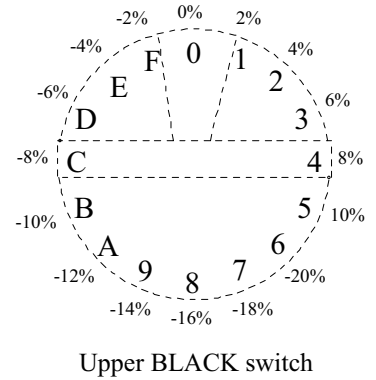

Upper BLACK switch

TROUBLESHOOTING

Series 7500/7600 8500/8600 9500/9600 Multifunction Instrument

BEFORE CALLING FOR ASSISTANCE, COMPLETE THESE TROUBLESHOOTING CHECKS AND RECORD YOUR FINDINGS. TECHNICAL SUPPORT REQUIRES THIS INFORMATION BEFORE A RETURN AUTHORIZATION WILL BE ISSUED. IT TAKES ABOUT 20 MINUTES AND IS VERY IMPORTANT IN ANALYZING SYSTEM PROBLEMS.

Before starting, record Instrument model number and switch settings.

MODEL # _____

SERIAL # _____

UPPER BLACK _____ RED _____ GREEN _____

LOWER BLACK or RECESSED ARROW _____

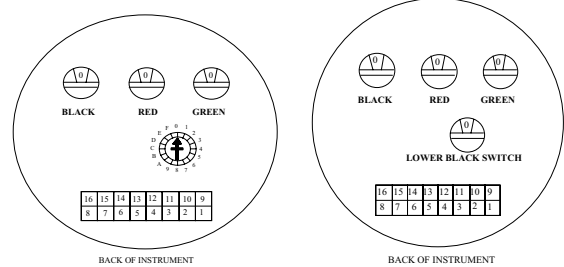

FAULT	PROBABLE CAUSE	SEE SECTION:
Blank LCD Display	Wiring	Sections II, III
No Back-Lighting	Wiring	Sections III
High or Low Totalizer reading. Over 10%.	Calibration	Calibration sheet
	Incorrect flow sensor	Operations sheet
	Incorrect switch settings	Calibration sheet
	Vacuum leak	Section IX
Fluctuating GPH Readings	Vacuum leak / Pulsations	Sections VIII, IX, X
No GPH or Totalizer Readings	Wiring	Sections II, V, VI
	Sensor orientation	Installation sheet, Section IV
High, Low or No Tachometer Reading	Wiring	Installation sheet, Section II
	Calibration	Calibration sheet
	Continuity	Section VI
	In-synch with engine or Glen Denning cable whip	Section VII
No Forward or Return Sensor Readings	Wiring / Instrument failure	Sections I, II, IV, V, VI
	Sensor Failure	Section I, IV
High Forward or Return Sensor Readings	Vacuum Leak	Section IX
	Incorrect switch settings	Calibration sheet
	Sensor orientation	Section XI

I. DIAGNOSTIC TEST:

1. Start engine(s). For 2 seconds after powering up, the Instrument will show all **8s**. During this time, quickly cycle the Totalizer-Reset Switch from its' run position to reset and back at least twice. This puts the Instrument into **Show Switches Mode** for 20 seconds. Record these readings below.

HOURS: _____ : _____

RPM: _____

GPH: _____

GALLONS: _____

After 20 seconds, the Instrument automatically goes into diagnostic mode. A minus sign (-) in the GALLONS window indicates when this occurs. The Instrument remains in diagnostic mode until power is secured.

IV. SENSOR(S) TEST

1. With engine(s) idling, measure and record voltage between the RED power and BLACK ground wires on the Forward Sensor. Voltage should be 12 to 14 VDC. _____ VDC
2. Move the voltmeters' negative lead to the WHITE signal wire. With engine idling, measure and record the voltage. It should be approximately 5 to 7 VDC, about ½ of the reading in step 1. _____ VDC
3. Stop the engine while observing your voltmeter. Readings should fluctuate between a high of 9 to 12 VDC, and a low of 0 to 4 VDC as the sensors' turbine slows to a stop. _____ VDC

NOTE: This may not be seen on digital voltmeters.

4. With engine(s) idling, measure and record voltage between the RED power and BLACK ground wires on the Return Sensor, (If used). Voltage should be 12 to 14 VDC. _____ VDC
5. Move the voltmeters' negative lead to the White (Signal) wire. With engine idling, measure and record the voltage. It should be approximately 5 to 7 VDC, about ½ of the reading in step 1. _____ VDC
6. Stop the engine and observe the voltmeter. Voltage readings should fluctuate between a high of 9 to 12 VDC, and a low of 0 to 4 VDC as the Sensors' turbine slows to a stop. _____ VDC

NOTE: This may not be seen on digital voltmeters.

7. The Sensor(s) may be defective if voltage readings in steps 3 & 5 remain constant. _____ VDC
8. If signal voltages in steps 3 & 5 are ok, go to the backside of the MFI Instrument. With engine(s) running, measure and record voltage across the Red & White, (Forward Sensor) and Red & Brown, (Return Sensor) signal wires. The MFI voltage readings should match the Sensor readings. This verifies that the Sensors' signal is reaching the MFI. If voltage is not present, there is a wiring problem. _____ VDC

V. MFI SENSOR INPUT TEST

1. Disconnect the WHITE and BROWN signal wires at the MFI Instrument harness. Connect a course thread, (½ -13) or similar non-plated bolt to the Black wire.
2. Run the WHITE wire up and down the bolt threads. This generates a pulse, which should make numbers in the GPH window start counting up. The totalizer should also eventually start counting. Faster movements give higher readings.
3. Run the BROWN wire up and down the bolt threads. This generates a pulse, which should make numbers in the GPH window start counting up. The totalizer should also eventually start counting. Faster movements give higher readings.

VI. CONTINUITY TEST

1. Continuity testing requires access to the back of the Instrument and an Ohmmeter. It verifies that wires are not broken, shorted to ground, another wire, or to power. Before starting, secure all power, and disconnect the Molex connector from the Instrument. This test checks the WHITE, BROWN, YELLOW, VIOLET, and BLACK wires.
2. Disconnect the WHITE and BLACK wire harness conductors from the WHITE and BLACK Port Sensor wires. Connect a jumper from the WHITE wiring harness conductor to a known good ground. At the Molex connector, connect an Ohmmeter lead to its' WHITE wire. Connect the other Ohmmeter lead to a known good ground. The Ohmmeter should read approximately 0.1 to 3 Ω. _____
(Ohm Reading)

3. Disconnect the BROWN and BLACK wire harness conductors from the WHITE and BLACK Starboard Sensor wires. Connect a jumper from the BROWN wiring harness conductor to a known good ground. At the Molex connector, connect an Ohmmeter lead to its' BROWN wire. Connect the other Ohmmeter lead to a known good ground. The Ohmmeter should read approximately 0.1 to 3 Ω . _____ (Ohm Reading)
4. Disconnect the YELLOW wire harness conductor from the Port Tachometer Sender. Connect a jumper from the YELLOW wiring harness conductor to a known good ground. At the Molex connector, connect an Ohmmeter lead to its' YELLOW wire. Connect the other Ohmmeter lead to a known good ground. The Ohmmeter should read approximately 0.1 to 3 Ω . _____ (Ohm Reading)
5. Disconnect the VIOLET wire harness conductor from the Starboard Tachometer Sender. Connect a jumper from the VIOLET wiring harness conductor to a known good ground. At the Molex connector, connect an Ohmmeter lead to its' VIOLET wire. Connect the other Ohmmeter lead to a known good ground. The Ohmmeter should read approximately 0.1 to 3 Ω . _____ (Ohm Reading)

VII. TACHOMETER PROBLEMS

Note: Refer to the engine owners' manual, wiring diagram, installation, and calibration instructions for parts A, B, & C below.

A. NO READING.

1. Check continuity of the YELLOW and VIOLET Tachometer signal wires, (Section VI). Verify that the tachometer signal wires are connected at the correct signal output point.
2. Disconnect either the YELLOW or VIOLET Tachometer signal wire from the Tachometer Sender. Connect an Ohmmeter to the two sender wires and measure its' resistance. AC Signal Generators should measure approximately 180 Ω , (\pm) 10%. Magnetic Pick-ups can measure between 100 to 800 Ω depending on manufacturer.
3. Next connect an AC Voltmeter to the sender wires. Both AC Signal Generator and Magnetic Pick-up senders should produce at least several volts at idle.
4. If the voltmeter reads "0" on an AC Signal Generator, it may not be properly attached to its drive port. Verify that its' drive shaft and tang are installed correctly.
5. If the voltmeter reads, "0" on a Magnetic Pick-up sender, it may not be installed correctly. With engine stopped, loosen its' lock nut. Turn the sender clockwise until it bottoms out. Back the sender out 1/8th to 1/4th turn. Turn the engine over by hand, or slowly jog it to verify adequate clearance.
6. Engine alternators tend to be an inaccurate Tachometer signal source, especially at low Rpm's. The engine may have to be revved up before the Tachometer will read.

B. HIGH OR LOW READINGS.

1. Verify that the Tachometer is calibrated correctly.

C. FLUCTUATING READINGS.

1. Listen to your engine(s). If engine speed cycles up and down, (when idling or underway) the tachometer reading will follow. This does not indicate a problem with the Tachometer, but may indicate engine problems.
2. Verify that wiring connections are tight, clean and dry. Check continuity while shaking the wires. Ohm readings should be near zero and remain steady while shaking.
3. Verify that the tachometer signal wires are connected at the correct signal output point.

VIII. PULSATION PROBLEMS

A stiff anti-siphon valve(s) or miss-plumbed Pulsation Damper(s) can cause fluctuating GPH readings. These are most pronounced at low Rpm's and tend to disappear around mid throttle. They are annoying, but won't affect totalizer accuracy. To eliminate, repair or replace any defective valves, or re-plumb dampers according to the Fuel Flow Schematic Instructions.

IX. FINDING FUEL SYSTEM VACUUM LEAKS

Fluctuating GPH and High Totalizer Readings are usually caused by a small vacuum leak between the fuel tank and fuel pump inlet. Fluctuations tend to be between 2 and 4 GPH. These vacuum leaks also affect totalizer accuracy, causing it to read 15 to 100% high. Larger leaks produce greater fluctuations and higher readings. They generally do not affect engine performance.

Finding suction leaks can be time-consuming. When approached properly, they can usually be found and repaired quickly. Two common places for suction leaks to occur are at the primary fuel filter - water separator, and/or a loose valve stem packing nut.

Remove the filter housing and coat all o-rings, gaskets and sealing surfaces with a medium to heavy grease, **(Do not use oil)** and reassemble. Grease all valve stem packings and gently tighten gland nuts. Don't over tighten, valve handles should turn freely. Tighten all hose clamps and compression fittings. Don't over tighten. Run the engine for 5 to 10 minutes observing GPH readings. If you've found the problem, fluctuations should be reduced to less than ½ GPH.

If the problem persists, temporarily install a clear piece of fuel resistant hose downstream of the forward flow sensor. Run the engine and watch for a stream of small bubbles in the clear hose, or an occasional larger bubble. Sometimes shining a light through the hose makes bubbles easier to see.

Observe the clear hose while shaking the fuel lines. If the bubble stream continually increases or decreases you've found the leak area. Repair or replace as needed. If this occurs one-time, you probably dislodged some trapped air.

If the leak hasn't been found, the last step is to inspect each pipe joint. Thread sealant should be visible around each joint. If not, that joint is suspect and must be resealed. After resealing run the engine for a few minutes to purge any remaining air. There should now be bubble free fuel running through the clear hose. If bubbles are still present a leak was missed. Recheck your work. After all the leaks are stopped, remove the clear hose.

X. Fuel Filters

A dirty Primary fuel filter, or one that is too fine (1-25 micron) will draw vapor bubbles out of the fuel, causing fluctuations and high readings. Replace it with a new 30-micron filter.

XI. FLOW SENSOR ORIENTATION

Sensor orientation is critical for proper operation. All Sensors have their inlet and outlet ports clearly marked (**IN / OUT** or **→ →**). This identifies fuel flow direction. The Sensor must be, "Plumbed" correctly for it to operate properly. There is an additional single arrow on the Sensor body. It is crucial that this single arrow points up **↑**.

XII. LOW RPM OPERATION

At idle, under a no load condition, it is common for GPH readings to fluctuate slightly. These fluctuations are caused by the engine governor regulating fuel flow to maintain a steady engine RPM.

XIII. NMEA 0183 Input, MPG, (Nautical) Miles per Gallon Problems:

Error Codes

Display	Reason	Cause
OFF	No signal activity present on NMEA 0183 terminals for four seconds	GPS / LORAN-C OFF NMEA OUTPUT not selected Leads not connected A & B leads reversed
- - -	Receiving valid NMEA 0183 Version 1.5 or 2.0 message, speed message invalid.	GPS satellite reception is poor GPS / LORAN-C in startup mode
- 0 -	Fuel flow reading below 0.1 GPH (LPH) (twin-both engines). Valid NMEA 0183 speed message present.	Engine(s) not running Fuel flow reading problem.
Er1	Some pulsing activity present. No valid NMEA 0183 message received in last four seconds.	Leads connected to wrong source GPS / LORAN-C set to NMEA 0180 or 0182 A & B leads reversed.
Er2	NMEA message detected. Missing "GPRMC" or "LCRMA" sentence.	GPS / LORAN-C incompatible with NMEA 0183, ver. 1.5 or newer

1. An **OFF** display in the GPH/MPG window indicates the FloScan Instrument isn't receiving a NMEA 0183 speed signal from the GPS. Check wiring connections to the GPS, and verify that it is turned on.
2. A Dash, Dash, Dash, (- - -) display indicates the GPS is in startup mode, or satellite reception is poor.
3. A Dash 0 Dash, (- 0 -) display indicates a valid NMEA 0183 speed message is present, but that fuel flow readings are so low the FloScan Instrument is unable to compute a meaningful MPG figure. Dash 0 Dash, (- 0 -) may be displayed when motoring at low speeds, or when slowing down. When slowing down the FloScan Instrument may display ever-increasing MPG readings, go to Dash 0 Dash, (- 0 -) and start redisplaying ever-increasing readings again.
4. **Er1** indicates that the FloScan Instrument isn't receiving a valid NMEA 0183 message from the GPS. Check wiring connections to the GPS.
5. **Er2** indicates that, "GPRMC" or "LCRMA" is missing from the GPS NMEA 0183-speed signal message. Verify the GPS sending a NMEA 0183 version 1.5 or newer signal.

**This concludes system testing. If problems with your system persist,
contact FloScan Technical Support with test results**

Flow Homogenizer Can Replacement

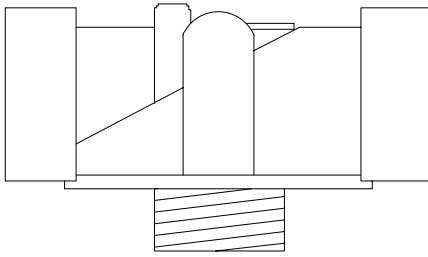

Aluminum Base

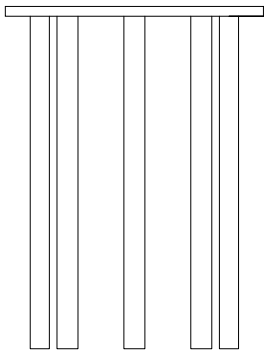

**Tube Assembly
P/N 4001-250-00**

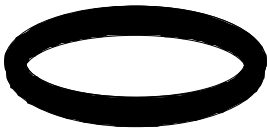

Rubber Sealing Washer

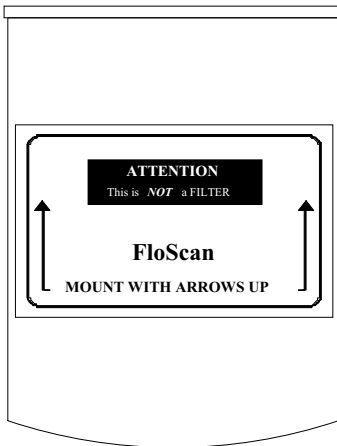

**Flow Homogenizer Can
P/N 4001-199-03**

1. Remove the old Flow Homogenizer can. A Claw type oil filter wrench, or pipe wrench may be needed.
 2. Remove the Brass Tube Subassembly and, Debris Screen, (If used) from the old can. Install them in new can.
 3. Put a coating of grease on the new Flow Homogenizer's rubber sealing washer.
 4. Clean the Aluminum base and put a coating of grease on the seal's mating surface.
 5. Place new Flow Homogenizer can on its Aluminum base. Turn until "Finger tight".
 6. Using a band type oil filter wrench, carefully rotate the can until tight, approximately $\frac{3}{4}$ of a turn past finger tight.
- Position a strip of rubber, (Bicycle tube or rubber glove) between the wrench and can. The rubber both increases friction and protects the can. Use caution as over-tightening will buckle or collapse the can.



INSTALLATION PLANNING



READ ME FIRST - Detailed Mechanical & Electrical Planning Saves Installation Hours!

FloScan K Series systems are not difficult to install. Installation requires only basic electrical & mechanical skills. With forethought and planning, your system will be installed with few problems. Todd Walker, Yacht Electric Co., (954) 325-9091 regularly installs FloScan K Series Twin Diesel Systems in about 10 hours. Difficult installations may take several hours longer.

I. Installation Preparation:

Review the pre-installation booklet, mechanical installation instructions, and survey your vessel. Determine where the Sensor(s), Sensor Assemblies, Switches and Instruments are to be mounted. Place them at their approximate locations. Determine fitting size and types required for each plumbing connection, (JIC, SAE, NPT, NPTF, or Hose Barb).

FloScan K-Series Hi-Cap Diesel Forward Sensor Assemblies have 1" Female NPT ports.

FloScan K-Series Hi-Cap Diesel Return Sensor Assemblies have 1" inlet and ½" outlet Female NPT ports.

FloScan Hi-Flo, (-10) Diesel and Gasoline Sensors have ½" Female NPT ports.

FloScan K-Series Lo-Flo Diesel and Gasoline System Components, (Sensors and Pulsation Dampers) have ¼" Female NPT ports.

Review the electrical installation instructions. Open and survey your vessels wire ways. Determine if it would be easier to run a 3-conductor cable from each sensor to the instrument, or install a junction box, (J-Box) with terminal strip in the engine room. The J-Box requires a 4-conductor cable from it to the instrument, and a 3-conductor cable from each sensor. Measure cable lengths from sensor(s) to J-Box, (If used) to Instrument. Tachometers require a separate 2-conductor cable. If there's an existing tachometer, its signal wires can be used.

II. Mechanical Installation:

Install or mount the Sensor(s) or Sensor Assemblies, Instruments and Switches, (Reset, MPG).

III. Plumbing:

Most K Series and -10 installations do not require additional fuel hose. Mount the sensor(s) or sensor assemblies where they're to be installed. On installations using **Fabric Braid A-1 Fuel Hose** install the correct HB X MNPT fitting into each sensor or sensor assembly. Always assemble fittings using a fuel proof pipe thread sealant. **Never use Teflon Tape.** Use a hose cutter or knife to cut the fuel hose. Next install the hose onto the barb fittings. Hose should not be twisted, have adequate slack, an ample radius at all bends and be supported at reasonable distances, approximately 2-4 feet. When clamping hose onto the barbs, use 2 narrow or 1 wide stainless hose clamp on each hose end.

Wire Braid A-1 Aeroquip Type Fuel Hose or Hydraulic Hose: Mount the sensor(s) or sensor assemblies where they're to be installed. Mark the hose where it is to be cut. Remove hose and bring it to a hydraulic shop. Have them cut the hose and install hose ends. Reinstall the hoses and install the correct fitting into each sensor or sensor assembly. Always assemble fittings using a fuel proof pipe thread sealant. **Never use Teflon Tape.** Hoses should not be twisted, have adequate slack, an ample radius at all bends and be adequately supported at reasonable distances, approximately 2-4 feet. AP-50 copper sealing washers, (Connie Seals) or Flaretite seals may be required to seal JIC & SAE fittings.

IV. Electrical Installation:

Run cables between Sensor(s), J-Box, (If used) and Instrument(s). Cables must be adequately supported at reasonable distances, approximately 2-4 feet.

Wire Terminations—Referring to the wiring diagram. Connect Sensor, Instrument and Switches to their respective wires with crimp type butt or ring connectors. Always cover connectors and wire ends with heat shrink tubing.

V. Pre-Startup:

Prime the fuel system. If you have an electric priming or boost pump, circulate fuel for 10 minutes while checking for leaks. If not, use the engines manual pump. Before starting, open the lift pumps' outlet fitting slightly. Before start-up, verify that all fuel system fittings are tight.

VI. System Start-Up:

Start and run your engines. Look for leaks and other installation problems. If system is not operating properly refer to the Troubleshooting Instructions and correct any deficiencies.

VII. Calibration:

When system is running properly, refer to the calibration instructions and calibrate your system. If installed properly, initial calibration takes less than 1 hour. After consuming some fuel, final calibration should only take a few minutes.

USCG approved fuel hose with either fabric or wire reinforcing braid meet the following standards:

<u>Hose Marking</u>	<u>Permeation Rating</u>	<u>2½ Minute Fire Test</u>
USCG Type A-1	100g/m²/24hrs.	Required
USCG Type A-2	300g/m²/24hrs.	Required
USCG Type B-1	100g/m²/24hrs.	Not Required
USCG Type B-2	300g/m²/24hrs.	Not Required

Table I

Installation Do's & Don'ts

Do	Don't
Use a Fuel Proof Pipe Thread Sealant when assembling fittings into fuel system components, (Loctite PST, Leak-Lock, or equivalent).	<u>Never use Teflon Tape!</u>
Use thin wall, low pressure, full flow type NPT or NPTF hose barb fittings.	Don't use Push-Lok, or Barb-Tite fittings. Avoid using JIC or SAE swivel fittings. If used always install copper conical sealing washers, (Connie seals) or fitting seals on fittings.
Double clamp all hose barb fittings.	Avoid using 90° elbow fittings.
Install Sensor(s) at a low point in the fuel system, as far from the engine as practical. Fuel must travel, "Up-hill" slightly after leaving the sensor. Verify correct orientation and fuel flow direction.	If possible, avoid bolting or mounting sensor(s) directly onto the engine.
Install Forward Sensors on the Fuel Pumps' Inlet or Vacuum side, and not on the pressure side.	If on the Pressure Side, Limit Sensor System Operating Pressure to 20 PSI or Less.
Always use 30-micron primary filters.	Avoid 2 or 5 micron primary filters.
Wire with Shielded Cable. Use a dedicated shielded pair for Magnetic Pickup Tachometer Senders.	Never use unshielded wires on Magnetic Pickup Tachometer Senders.
Connect all, "Ground" wires to a Ground Buss, or directly to the Battery's Negative Terminal. Connect or, "Ground" wire shields to the engine block.	Never connect Instrument or Sensor "Ground" wires to the hull, engine block, or other machinery.
On Instruments with a GPS interface, connect FloScan's Data (+) to the GPS signal output. Connect Data (-) to the GPS signal ground.	Do not connect FloScan's Data (-) to the GPS Data (-).
Always use non-illuminated switches for Totalizer Reset, Port/Starboard Select, Hours/Synch, and GPH/MPG.	Never use illuminated, or back-lit switches.

Series 7500(0)/7600(0), 8500(0)/8600(0), 9500(0)/9600(0) Temperature Compensated, & Non-Temperature Compensated Magnetic Pickup & AC Signal Generator Type Tachometer Sender Instruments

Series 7500(0)/7600(0), 8500(0)/8600(0), 9500(0)/9600(0) Diesel Multifunction Instruments use a microprocessor-based, non-volatile Random Access Memory (RAM) to store engine hours and gallons of fuel consumed. Non-volatile RAM requires no power for memory retention.

All “8”s are displayed for the first 3 seconds when the instrument is powered up. For 1 second after that, the instrument shows switch positions and software version. After completing its start-up sequence, the instrument goes into normal operating mode.

If supply voltage drops below 10V DC for any reason, the instrument displays a row of decimals across the bottom of the RPM window. This does not affect instrument accuracy. Stored engine hours and fuel consumption data will not be lost.

Liquid crystal displays have an OPTIMUM VIEWING ANGLE. If your viewing angle is outside this range, contrast will decrease and numbers may flicker.

Before drilling any holes in your dash, it's a good idea to temporarily power up the instrument (+12V DC to the RED wire on plug #9, 12V DC to the BLACK wire on plug #5) before installing it and see if the intended viewing angle is acceptable.

Engine Hours

The engine hours meter is shipped at or near zero hours. It accurately tracks the number of hours your engine has run. Unlike most hour meters, it only accumulates time when the engine is actually running. If the meter is turned ON, but the engine is NOT running, NO time is added to the engine hour display.

The engine hour meter cannot be reset.

Tachometer (RPM)

The Tachometer window shows engine speed in RPM and is accurate to within $\pm 1\%$ (belt driven alternator tachometer signals are only accurate to ± 50 RPM).

Flow Consumption (GPH, LPH)

The GPH/LPH window shows the rate at which your engine is consuming fuel. The GPH/LPH and Gallons/Liters readings will both change if the flow calibration switch (UPPER BLACK SWITCH) on the back of the instrument is turned.

Totalizer (Gallons, Liters)

The Gallons/Liters window shows total fuel consumed. The GPH/LPH and Gallons/Liters readings will both change if the flow calibration switch (UPPER BLACK SWITCH) on the back of the instrument is turned.

Totalizer Reset

When the totalizer-reset switch is turned ON (Closed), the GALLONS/LITERS display will flash for ten seconds, then reset to zero. Flashing indicates the instrument is in reset mode. If the RESET switch is turned OFF (Opened), before the totalizer reads “0.0”, the instrument will NOT reset. If you neglect to turn OFF the RESET switch, “0.0” continues to flash.

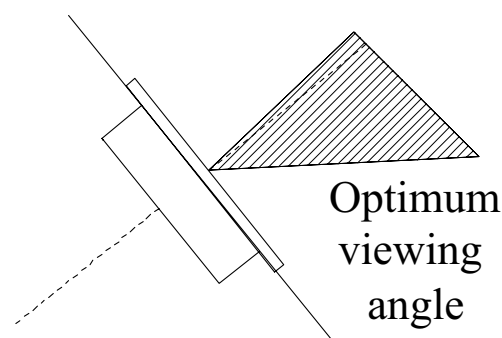

AC Signal Generator, (G) Type Only

**750G/760G, 75TG/76TG, 750G0/760G0, 75TG0/76TG0
 850G/860G, 85TG/86TG, 850G0/860G0, 85TG0/86TG0
 950G/960G, 95TG/96TG, 950G0/960G0, 95TG0/96TG0**

Type "G" Diesel Multifunction Instruments are preset for the correct flow sensor combination. Before installing the instrument, verify that the switch settings are correct for your application. Flow Sensor types are coded as part of your kit model number.

Recessed "Arrow" Rotary Switch Settings			
<i>Switch Position</i>	<i>Flow Sensor</i>	<i>Switch Position</i>	<i>Flow Sensor</i>
0	CAT 265/265	8	233B/233B
1	RTY 265/201	9	233C/233C
2	265/231	A	233D/233D
3	231/231	B	233E/233E
4	201/201	C	233F/233F
5	BOS 231/201	D	Cummins 231*
6	All 235/236 & 233 B-C, C-D, D-E, E-F, and combinations	E	Cummins 233C*
7	233A/233A	F	Cummins 233D*

*Cummins Engines with PT pump injection system using one flow sensor in the feed line to the engine.

INSTALLATION

MECHANICAL & WIRING OVERVIEW, (K Series & -10 Systems)

To Ensure System Accuracy, Follow All Installation Instructions.

- Sensor Placement.** Determine where the Flow Sensor, or Flow Sensor-Pulsation Damper assembly is to be installed. Install the sensor, or sensor-pulsation damper assembly so that the two fuel flow arrows, (→ →) or the, (IN and OUT) markings are on a horizontal plane. All orientation arrows, (↑) must be pointing up. The forward sensor or forward sensor-pulsation damper assembly must be installed downstream of the primary filter. Do not install the sensor or either sensor assembly at a high point in the fuel system. This could negatively impact system accuracy by trapping air. The fuel return line between the return sensors' outlet port and fuel tank should be at least 12" long and have a 1 to 2" upward rise. This keeps the return sensor flooded, improving accuracy. Place sensor assemblies in a protected location away from water spray.

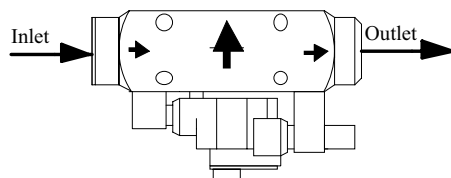
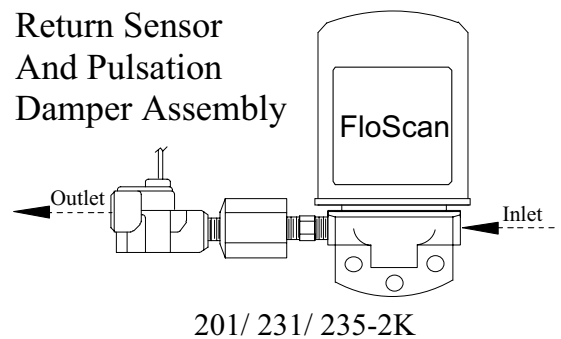
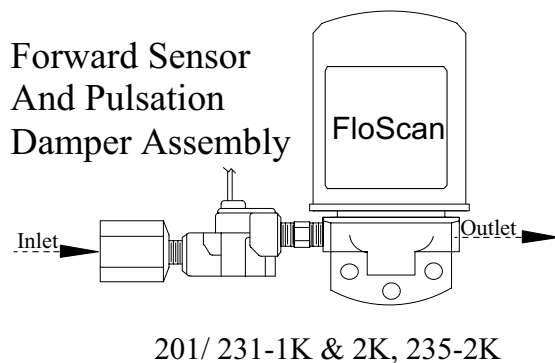
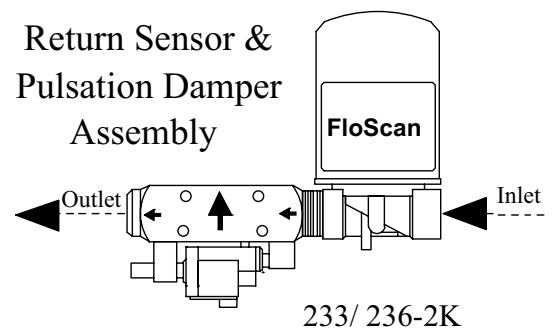
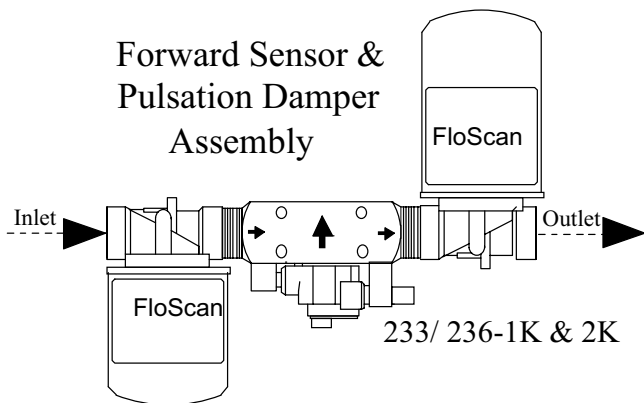

233C-10 & 233D-10 (Cummins PT Systems)

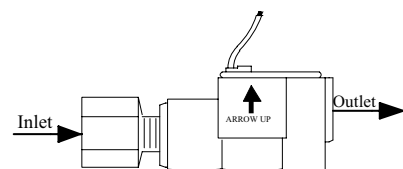

231-10 (Cummins PT Systems)

- **Determine fitting type & size.** Minimize the number of elbows and fittings. If swivel fittings are used, (JIC or SAE) their mating surfaces must be sealed with Copper Conical Sealing Washer, (Connie Seals) or fitting seals. Fitting seals may be purchased through Fittings Inc. in Seattle, WA (206) 767-4670, 1-800-552-0632, or a local hydraulic supply house.



- **Select Instrument Mounting Location.** The instruments' face is waterproof and a gasket is provided to seal its bezel to the control panel. Choose a location away from the compass. Install 65/6600 series instruments 12" away from compass. Choose a shaded location since direct sunlight may cause the LCD display to temporarily turn. This does not damage the LCD, but makes it impossible to read until cooling down. Make a cutout in the instrument panel for the instrument. The instruments' maximum depth is 3 1/2" minus the thickness of the console panel.

Instrument Series	Cutout Size
6500/6600	3 1/16"
7500/7600, 8500/8600, 9500/9600, TwinScan	3 3/8"

- **Wiring.** Determine wiring run length and the number of switches needed, (always use good quality marine grade switches). Use 18 AWG conductors on runs under 50'. 16 AWG for runs over 50'.
- **Run & Connect Wires.** Wire one system at a time. Always begin with the Black, "Ground" wires. Each Black sensor wire must be connected to the Black, "Instrument Ground" wire. Use a single wire to connect these Black wires to the battery's negative terminal, or to the ground buss. **For the system to operate properly the, "Ground" wires must be connected in this manner.** Connect other wires per the wiring diagram. Leave the RED, power wire for last.
- **Tachometer Installation Options.** 75/7600, 85/8600, and 95/9600 series tachometers require one or two additional wires. If your engine isn't equipped with a tachometer sender determine which type it requires, (AC Signal Generator or Magnetic Pickup) and install one. Some engine alternators produce a tachometer signal and can be used as the tachometer sender. Mechanically driven AC signal generators and magnetic pickups are available from FloScan and most marine dealers. Hewitt, Motorola, VDO and Stewart Warner are some of the more common brands.
 1. **Keep Existing Tachometer(s).** Connect the FloScan tachometers' Yellow and Violet signal wires to the existing tachometer. If the tachometer sender wire(s) are not marked, trace them from the tachometer sender up to the existing tachometer. If one sender lead is grounded, connect the FloScan tachometers Yellow signal wire to the ungrounded lead or terminal. Connect the VIOLET wire to a Ground Buss, or Battery Minus.

2. **Replace Existing Tachometer(s).** FloScan MFI instruments have a 3 3/8" outside diameter. This is a common size and fits into most instrument mounting holes. Identify the engines' tachometer sender wires. Connect the FloScan tachometers' Yellow and Violet signal wires to the sender wires. If one sender lead is grounded, connect the FloScan tachometers' Yellow signal wire to the ungrounded lead or terminal. Connect the VIOLET wire to a Ground Buss, or Battery Minus.
3. **New Tachometer(s).** Run a dedicated shielded pair of wires between the instrument and tachometer sender, (This is especially important with Magnetic Pickup senders). Ground the shield only in the engine room.
 - **Magnetic Pickup & AC Signal Generator Tachometer Senders:** Connect the FloScan tachometers' Yellow signal wire to one sender terminal. Connect the Violet wire to the other terminal.
 - **Engine Alternators:** Connect the FloScan tachometers' Yellow signal wire to the alternators' tachometer output terminal. This terminal is usually marked as **TACH**, or **SIG**. Connect the VIOLET wire to a Ground Buss, or Battery Minus.
- **Pre-Startup & Installation Check.** Prime the fuel system. If you have an electric priming or boost pump, circulate fuel for 10 minutes while checking for leaks. If not, use the engines manual pump. Before starting, "Crack" the lift pumps' outlet fitting slightly. Continue pumping until system is fully primed. Before start-up verify that all fuel system fittings are tight.
- **System Start-Up.** Start and run your engines. Survey the installation for leaks and other problems. If the system is not operating properly refer to the Troubleshooting Instructions and correct any deficiencies. When the engine reaches operating temperature increase engine speed to about 1500-2000 RPM. Letting it run for five or ten minute's helps purge residual air from the system.
- Any vacuum leaks between the fuel tank and lift pump will allow air to be drawn into the system. These leaks cause high and/or fluctuating GPH readings. Only severe leaks affect engine performance, but all leaks affect sensor performance and instrument readings. Vacuum or suction leaks occur at improperly sealed primary filters, loose packing nuts on cross over & shut off valves and improperly sealed fittings. Vacuum leaks can also occur from corroded copper fuel lines and chaffed fuel hose, (where it rubs against bulkheads or engine parts). To verify that a suction leak is present, temporarily insert a clear piece of fuel resistant tubing downstream of the Forward Sensors' outlet. Observe the clear hose for at least two minutes looking for bubbles. Bubbles can appear as a constant stream of small bubbles, or as an occasional larger bubble. Tighten all possible leak sources, grease primary filter seals and install fitting seals on JIC/SAE fittings. Continue to observe the clear tubing until it runs clear without any bubbles. Flex or wiggle rubber hose sections while observing the clear tubing. If bubble volume increases inspect the hose and check its fittings. Repair as necessary.
- When idling in neutral, (No Load) GPH fluctuations can also be caused by the governor trying to maintain a steady engine RPM.
- **Calibration.** When the system is running properly, refer to the calibration instructions and calibrate your system. If installed properly, initial calibration takes much less than 1 hour. After consuming some fuel, final calibration should only take a few minutes.

Fuel Flow Schematic – High Capacity Diesel Systems, (233 & 236-2K)

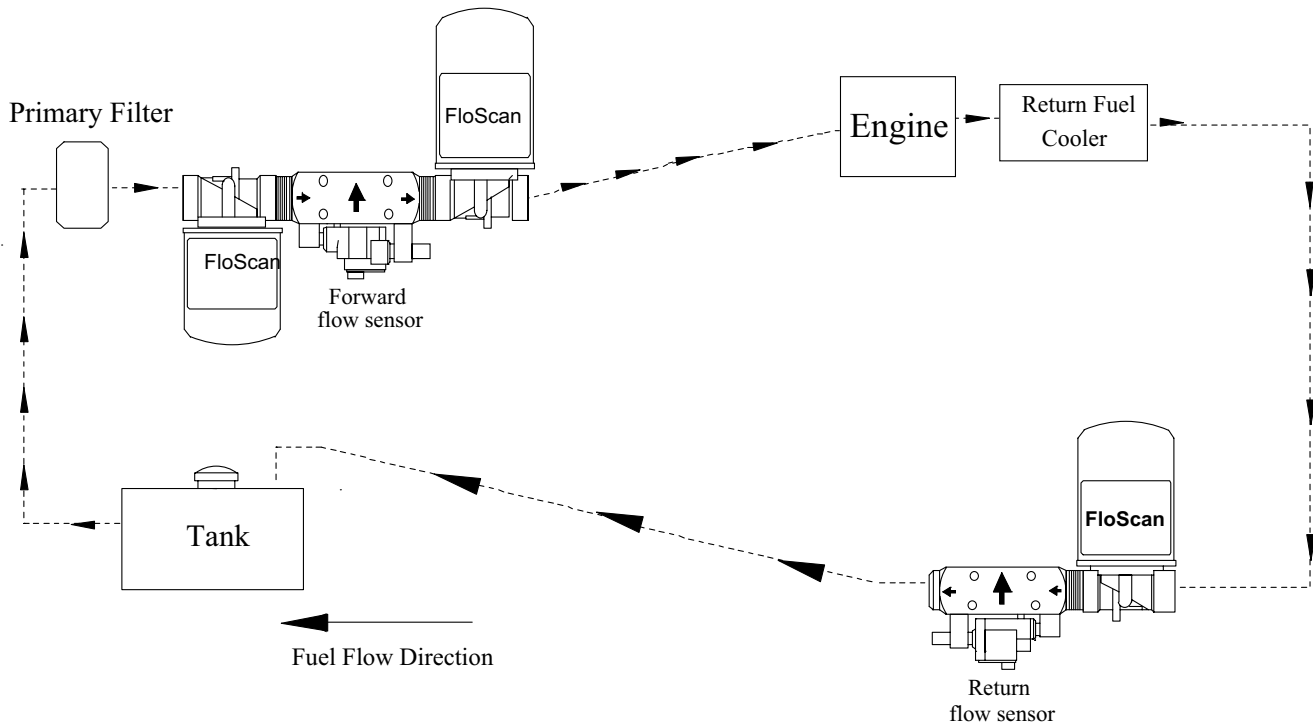

***Caution: Diesel System Components are not designed for use on Gasoline Fuel Systems.**

FloScan Sensor & Pulsation Damper Plumbing Guidelines:

1. Install flow sensor & pulsation damper assemblies with their orientation arrows pointing UP ↑. Fuel must enter through the port marked with an inward pointing arrow, (→←) and exit through the port marked with an outward pointing arrow, (←→). Install the sensor – pulsation damper assembly as far from the engine as practical. Maximizing fuel line length between engine and sensor – pulsation damper assembly improves instrument accuracy.
2. Maintaining high flow velocities through the fuel lines minimizes sensor oscillations. Use the smallest approved fuel line diameter for your engine, especially on the return line. Consult the engine owners' manual for more information. To insure that the return sensor remains flooded, install the return sensor – pulsation damper assembly at a low point in the system. Fuel should travel "Up-Hill" upon exiting the return sensor.
3. Flow sensors must always be installed downstream of a filter or debris screen (no finer than 30 micron). Particles larger than 1200 microns may jam the sensors' rotor and cause it to fail.

4. Flow sensor model numbers are molded into the colored plastic wire cap. Sensors are labeled FORWARD and RETURN and must be installed in these positions for proper operation. A single stand-alone letter stamped into the sensors' body identifies its match code.
5. Model *236 sensors are temperature compensated and marked with their Instruments serial number, xxxxF (Forward), xxxxR (Return). *236 Temp-comp sensor kits are precisely calibrated and matched to each instrument. The instrument head serial number must match the flow sensor(s) serial number.
6. If there's a shut-off valve in the return line, do not operate the engine with it closed. Fuel system pressure could exceed the systems working pressure of 40 PSI, and may cause a catastrophic system failure. You should either tag the valve so the engine will not run when it is closed for maintenance, or bypass it with a relief valve.

NOTE: Minimize the number of 90° elbows and pipe fittings. Excessive use may create a high vacuum, fuel restricting, pressure drop across the forward part of the fuel system. Refer to the engine owners' manual for maximum, fuel pump inlet vacuum. A vacuum gauge can be used to confirm that the system is within limits.

CAUTION: DO NOT OVER TIGHTEN FITTINGS. Torque sensor and pulsation damper pipe thread fittings to a maximum of 15 ft.-lb. (180 inch-lb.), or 2 full turns past hand tight, whichever comes first. Leak Lock pipe thread sealant is provided with your system. Use it on all pipe thread fittings. **DO NOT USE TEFLON TAPE.**

TEMPERATURE COMPENSATED		
Forward Sensor	Return Sensor	Kit
*236F	*236E	*6FE-2K
*236E	*236D	*6ED-2K
*236D	*236D	*6DD-2K
*236C	*236C	*6CC-2K
*236C	*236B	*6CB-2K
*236B	*236B	*6BB-2K

NON-TEMPERATURE COMPENSATED		
Forward Sensor	Return Sensor	Kit
233F	233E	3FE-2K
233E	233D	3ED-2K
233D	233D	3DD-2K
233C	233C	3CC-2K
233C	233B	3CB-2K
233B	233B	3BB-2K

BRACKET ASSEMBLY

1K & 2K Hi-Cap Forward Sensor Bracket Assembly

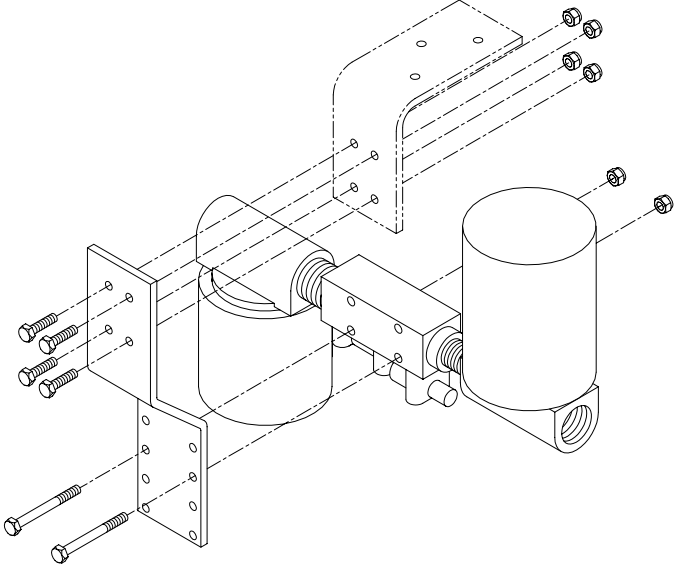
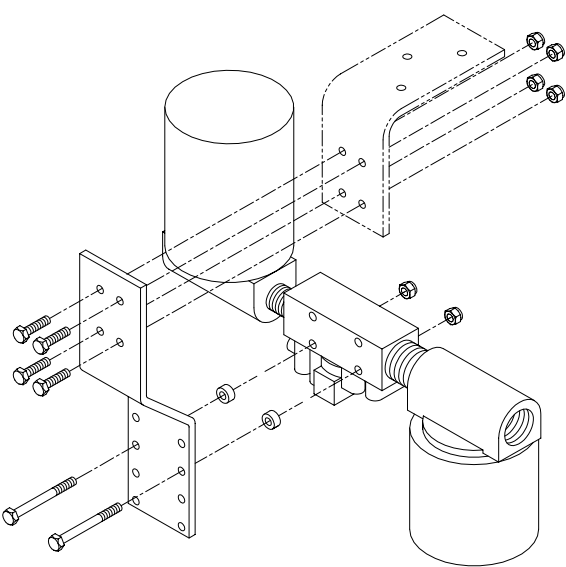
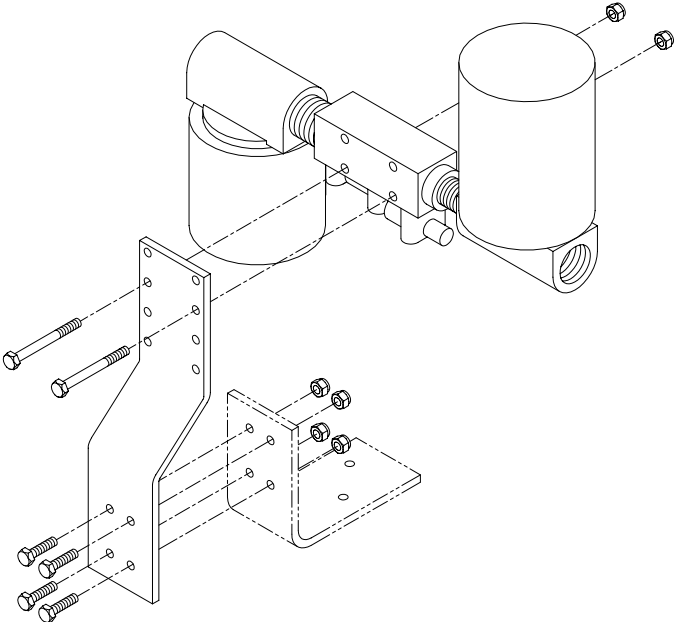
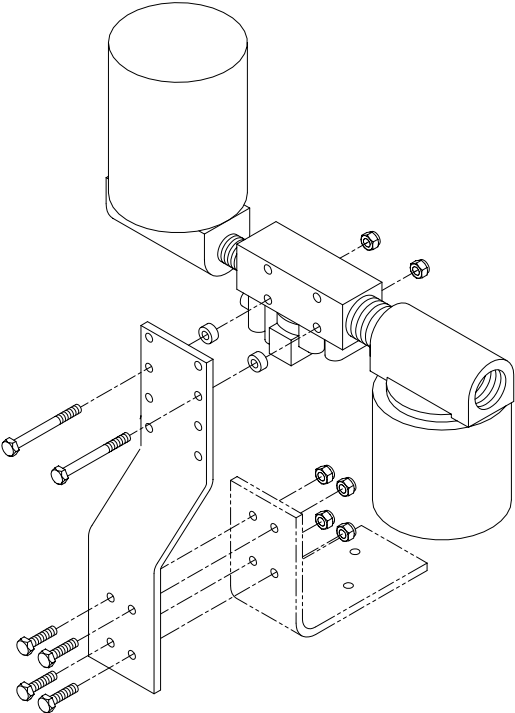

- 90° angle bracket part number 4001-357-00 and mounting hardware available upon request.

(Please see reverse for Return Sensor Bracket Assembly)

BRACKET ASSEMBLY

2K Hi-Cap Return Sensor Bracket Assembly

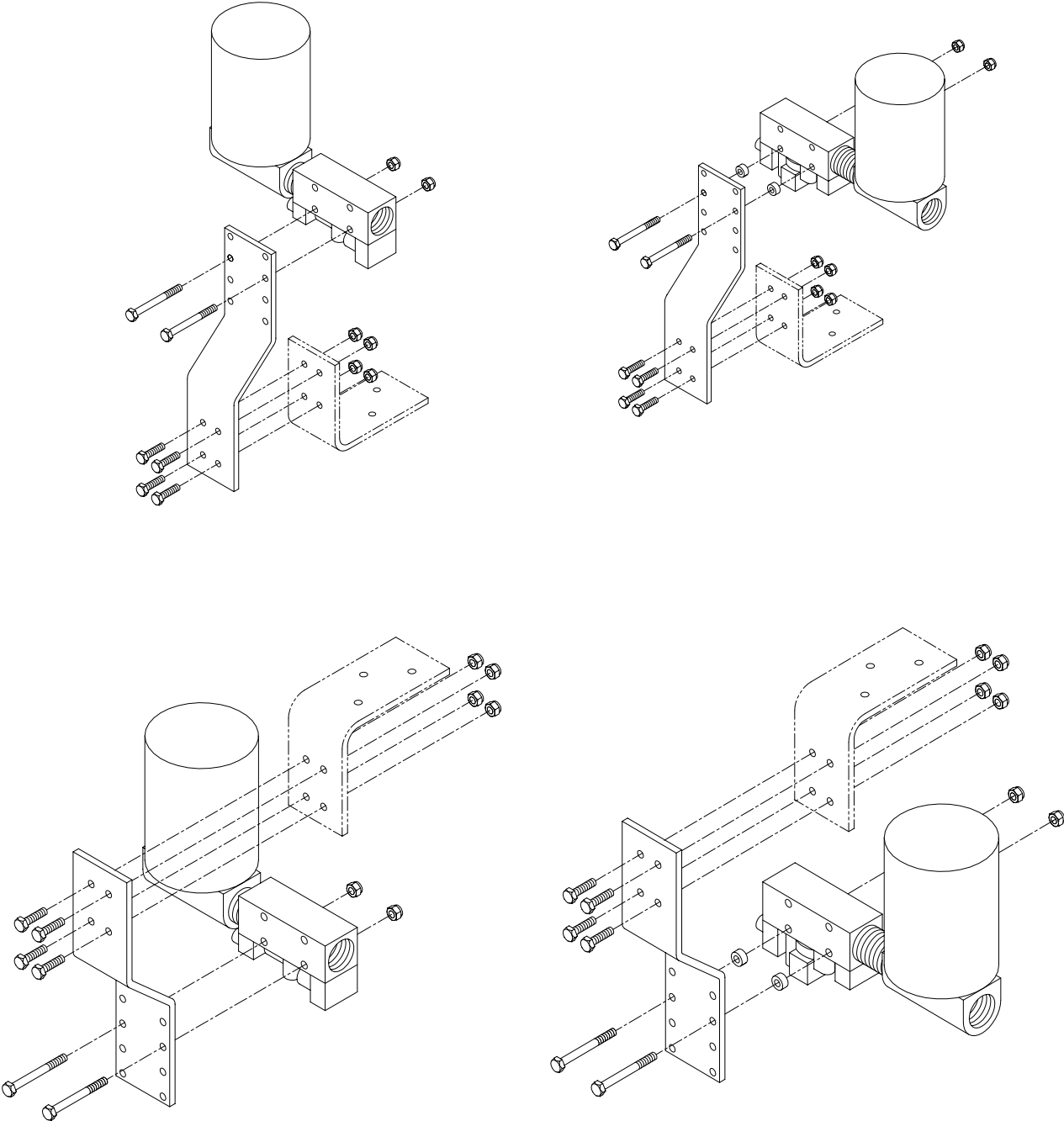

- 90° angle bracket part number 4001-357-00 and mounting hardware available upon request.

INSTALLATION

Series 9500/9600 Multifunction Instrument Diesel - NMEA 0183 Input

This unit conforms to NMEA 183, Version 1.5 and 2.0 interface standards and requires a message that includes "GPRMC" or "LCRMA". Check your owners manual to verify your GPS / LORAN-C includes this information. To insure an easy trouble free installation, read all instructions before starting

Wiring:

NMEA 0183 Connections:

1. Refer to the electrical wiring section of the GPS / LORAN-C Owner's Manual for the proper procedure to connect your GPS/LORAN-C to NMEA 183 devices. Use shielded wire between instruments and ground the shield ONLY at the GPS / LORAN-C (sender end), not at the FloScan instrument end (receiver end). The shield is not to be used as a ground path.
2. Connect the WHITE/ORANGE wire (terminal #15, FloScan instrument) to the NMEA "A" (BNC center terminal) terminal coming from your GPS / LORAN-C instrument.
3. Connect the GREEN/BLACK wire (terminal #7, FloScan instrument) to the NMEA "B" (BNC shield) terminal coming from your GPS / LORAN-C instrument.
4. Connect the GRAY wire (terminal #2, FloScan instrument) to one terminal of a single pole, single throw switch. Connect the BLACK wire (terminal #13, FloScan instrument) to the other terminal.
5. For single engine installations, the RED wire (terminal #1) is not used and should be taped off.

Calibration:

1. See your GPS / LORAN-C owners manual and set output for NMEA 0183. Speed is always sent as speed over ground in knots no matter what units your GPS / LORAN-C displays.
2. Fuel flow rate used in the MPG calculation is automatically done when the totalizer(s) are calibrated. To calibrate, see the Totalizer calibration instruction page.

MPG/GPH Operation:

With the MPG/GPH switch in the OFF position, your instrument displays engine fuel flow (in twin engine installations, each instrument displays fuel rate and total consumption only for the engine on which it is installed). In the ON position, fuel mileage (speed over ground in Knots /all fuel being consumed) is shown as "0.00 " to "9.99 ", then "10.0 " to "99.9 ". You must have valid NMEA 0183 speed and a total flow rate of at least 0.1 GPH (LPH) to display fuel mileage or you receive an error code:

Error Codes:

Display	Reason	Cause
OFF	No signal activity present on NMEA 0183 terminals for four seconds	GPS / LORAN-C OFF NMEA OUTPUT not selected Leads not connected A & B leads reversed
- - -	Receiving valid NMEA 0183 Version 1.5 or 2.0 message, speed message invalid.	GPS satellite reception is poor GPS / LORAN-C in startup mode
- 0 -	Fuel flow reading below 0.1 GPH (LPH) (twin-both engines). Valid NMEA 0183 speed message present.	Engine(s) not running Fuel flow reading problem.
Er1	Some pulsing activity present. No valid NMEA 0183 message received in last four seconds.	Leads connected to wrong source GPS / LORAN-C set to NMEA 0180 or 0182 A & B leads reversed.
Er2	NMEA message detected. Missing "GPRMC" or "LCRMA" sentence.	GPS / LORAN-C incompatible with NMEA 0183, ver. 1.5 or newer

PULSE OUTPUT INSTRUCTIONS

Series 8500/8600 Diesel Multifunction Instrument

NOT FOR 9500/9600 OR TWINSCAN COMBINATION INSTALLATIONS

The 85/8600 series Pulse Output Multifunction Instrument (MFI) produces a 1000 pulse per liter, or 3785 pulse per gallon output signal. During normal operation this signal equals the engines fuel consumption. In diagnostic mode zero fuel flow is transmitted. The signal output is optically isolated, which helps to minimize noise interference.

WIRING:

Single Engine Installation

1. Connect the WHITE/RED wire from pin 2 to the GPS fuel "SIGNAL" input.
2. Connect the GREEN/BLACK wire from pin 7 to the GPS "REFERENCE" input.

Twin Engine Installation

1. Select the MFI that is physically closest to the GPS.
2. Connect its WHITE / RED wire from pin 2 to the GPS fuel "SIGNAL" input.
3. Connect its GREEN / BLACK wire from pin 7 to the GPS fuel "REFERENCE" input.
4. Connect the WHITE / RED wire from pin 2 of the second MFI to the WHITE / YELLOW wire from pin 3 of the first MFI.
5. Connect the GREEN / BLACK wire from pin 7 of the second MFI to the BLACK wire from pin 5 of the first MFI.

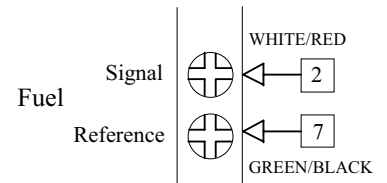

PC or other Equipment, Setup and Operation:

Connect Pin 2, WHITE / RED wire, to the computer or equipment's signal input. If the input does not supply pull-up current, Pin 2 must also be connected to +12 VDC, through a 10K – 47KΩ pull-up resistor.

Connect Pin 7, GREEN/BLACK wire, to the PC, or other equipment's **Ground**. If the FloScan MFI is used as the pull-up power supply, Pin 7 must also be connected to the BLACK wire on Pin #5, (Instrument Ground).

GPS Output Calibration:

The GPS output requires no special calibration. Calibration of the MFI totalizer automatically calibrates the GPS output signal.

GPS SETUP AND OPERATION:

GPS setup and operation information is located in the GPS user manual. Select a Presentation screen from the setup menu and program in the fuel volume unit desired. Go to the Sensor Control screen and set the fuel flow sensor to Pulse. Set conversion to:

1000p/Liter
3785p/Gallon
4546p/UK or Imperial Gallon

When not locked onto a satellite, the GPS goes into, "Hunt Mode". Screen readings may freeze until it locks onto a satellite. If this occurs, changing to a different screen then back should update the original screen.

- The WHITE / RED and GREEN / BLACK wires are twisted to prevent noise interference. If they are not long enough to reach the GPS, cut them back to 3". Use a shielded wire to connect the GPS and MFI. Connect the shield to the GPS, "REF" terminal.

Series 5500(0)/56100/5800(0)/6500(0) CruiseMaster, All Multi Function Instruments, & TwinScan®

SET UP

Wire & Switches: Use 18 AWG stranded wire on runs under 50'. For runs over 50' use 16 AWG, (Shielded wire is recommended for all Diesel systems, and suggested for Inboard & I/O gasoline systems. Always, "Ground" wire shield or shield drain wire in the engine room by connecting it to the bonding system, or engine block). The double wiring harness for twin engine Pulse/NMEA Diesel installations is included in all, (97/9800(0)) kits. FloScan suggests using J-Boxes, Terminal Blocks, and three conductor cables between the sensors and instrument to make wiring easier.

Install Single Pole Single Throw (SPST) switches for Totalizer Reset, Port-Starboard Select, Engine Hours / Synchronizer, and GPH / MPG, (switches are not included in kit). To determine which switch types are required for your system, refer to the table below. All instruments except TwinScan Tachometers require a totalizer reset switch.

SYSTEM	TOTALIZER RESET	PORT/STBD (Twin Systems)	HOURS/ SYNCH	GPH/ MPG	MPG/ SYNCH
2500	SPST or Momentary ON	SPST	NA	NA	NA
5500	SPST or Momentary OFF	SPST	NA	NA	NA
5800	SPST or Momentary OFF	NA	NA	NA	NA
6500/6600	SPST or Momentary OFF	SPST Twin Cummins (PT) only	NA	NA	NA
ALL 7XXX or 8XXX MFI	SPST or Momentary ON	SPST	SPST	NA	NA
All 9XXX MFI	SPST or Momentary ON	SPST	SPST	SPST	NA
TwinScan GPH	SPST or Momentary ON	NA	NA	NA	SPST w/ both
TwinScan Tach	NA	NA	NA	NA	GPH & Tach

NA = Not Applicable

Grounding: Each Black sensor wire must be connected directly to the Black, "Instrument Ground" wire. Use a single wire to connect the Black wire junction to the battery's negative terminal, or a ground buss.

Power: FloScan Instruments & sensors operate on 9 to 12 VDC. Voltages exceeding 16 VDC will damage the equipment. 24 & 32 VDC systems must be reduced to 12 VDC. Two different types of voltage reducers are available through FloScan.

CONNECT THE WIRES

Installation: Connect wires one at a time and Install heat shrink before proceeding to the next wire, (refer to wiring diagram). Connect ground wires first, (BLACK instrument ground wire to the BLACK sensor wires. Connect this junction to the battery's negative terminal or the ground buss). Connect all other wires leaving the Red power wires for last to prevent short circuits during the installation.

Splicing: Splice or join individual wires per the diagram. Slide heat shrink tubing over the splices to prevent shorts. Do not seal splices until the installation is finished and has been tested.

An adequate number of crimp-on connectors and heat-shrink tubing are included with system. The heat-shrink is a special type that will bond to wire insulation and make a watertight connection. See diagram for proper tubing application. Crimp-on connectors are sized for 18 or 20 gauge stranded wire.

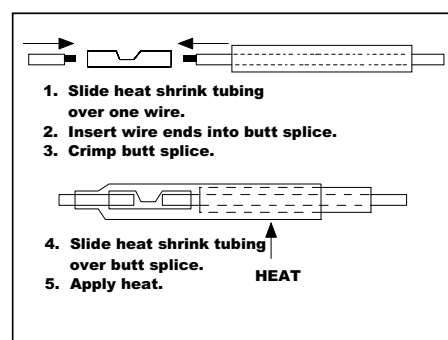

FINAL ACTIONS

Check Electrical Installation: Test all connections. Support and secure all dangling wires. Start engine and calibrate system.